

Panasonic

DVCPRO

Digital Camera Recorder

AJ-D215P

Operating Instructions

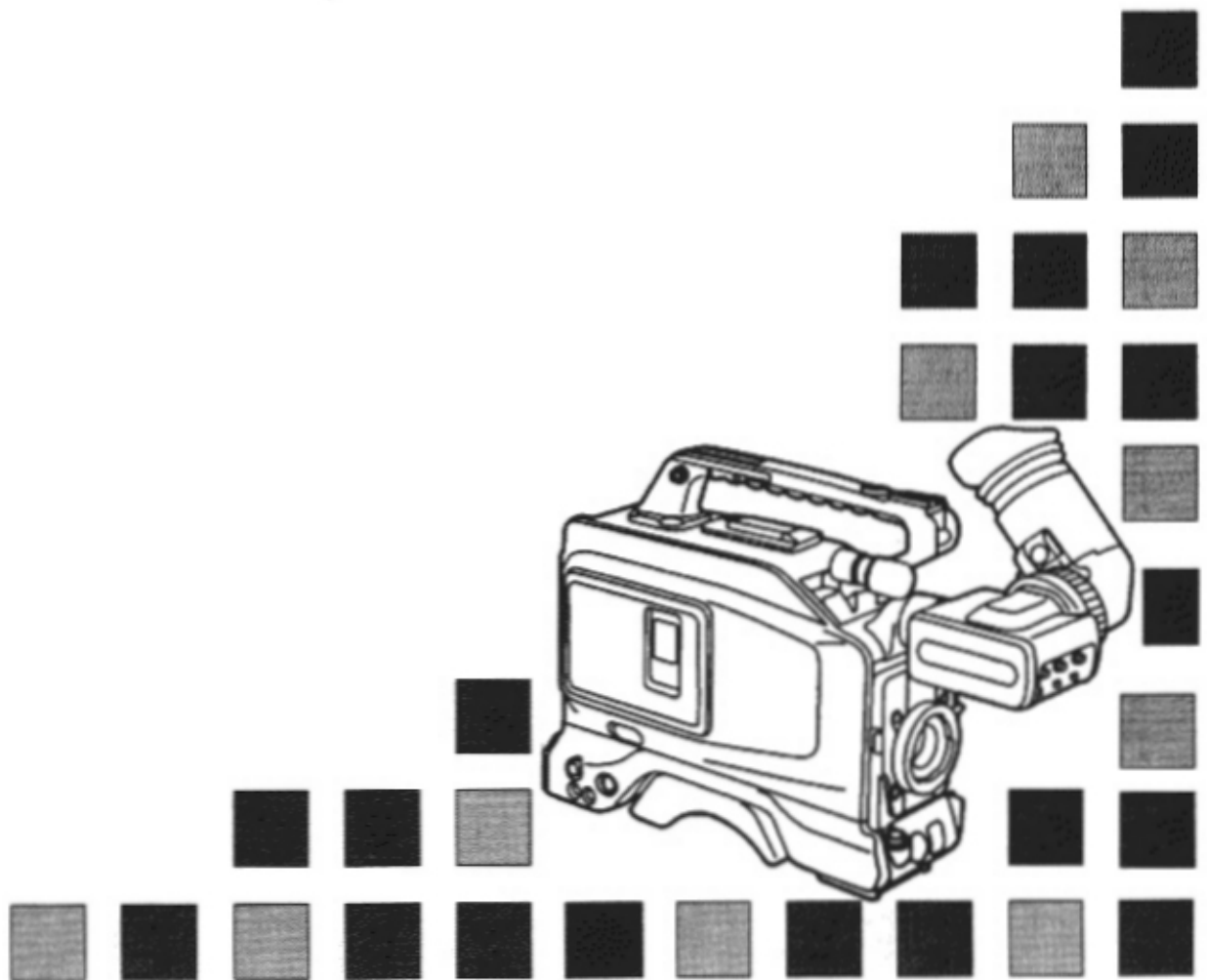

■ **DO NOT REMOVE PANEL COVER BY UNSCREWING.**

To reduce the risk of the electric shock, do not remove cover. No user serviceable parts inside. Refer servicing to qualified service personnel.

WARNING:

TO REDUCE THE RISK OF FIRE OR SHOCK HAZARD, DO NOT EXPOSE THIS EQUIPMENT TO RAIN OR MOISTURE.

CAUTION:

TO REDUCE THE RISK OF FIRE OR SHOCK HAZARD AND ANNOYING INTERFERENCE, USE THE RECOMMENDED ACCESSORIES ONLY.

Lithium Battery

Warning

The lithium battery in this equipment must only be replaced by qualified personnel. When necessary, contact your local Panasonic supplier.

"The lithium battery is a critical component (type number CR2032 or BR2032 manufactured by Panasonic.)

It must never be subjected to excessive heat or discharge. It must therefore only be fitted in equipment designed specifically for its use.

Replacement batteries must be of the same type and manufacturer. They must be fitted in the same manner and location as the original battery, with the correct polarity connections observed.

Do not attempt to re-charge the old battery or re-use it for any other purpose. It should be disposed of in waste products destined for burial rather than incineration."

CAUTION

Danger of explosion if battery is incorrectly replaced.

Replace only with the same or equivalent type recommended by the equipment manufacturer. Discard used batteries according to manufacturer's instructions.

VARNING

Explosionsfara vid felaktigt batteribyte. Använd samma batterityp eller en ekvivalent typ som rekommenderas av apparattillverkaren. Kassera använt batteri enligt fabrikantens instruktion.

ADVARSEL!

Eksplussionsfare ved fejlagtig håndtering. Udskiftning må kun ske med batteri af samme fabrikat og type. Levér det brugte batteri tilbage til leverandøren.

VAROITUS

Paristo voi räjähtää, jos se on virheellisesti asennettu.

Vaihda paristo ainoastaan laitevalmistajan suosittelemaan tyyppiin. Hävitä käytetty paristo valmistajan ohjeiden mukaisesti.

 indicates safety information.

Attention/Attentie

- Batteries are used for the main power source and memory back-up in the product. At the end of their useful life, you should not throw them away. Instead, hand them in as small chemical waste.
- Voor de primaire voeding en het reservegeheugen van het apparaat wordt gebruikgemaakt van een batterij. Wanneer de batterij is uitgeput, mag u deze niet gewoon weggoien, maar dient u deze als klein chemisch afval weg te doen.

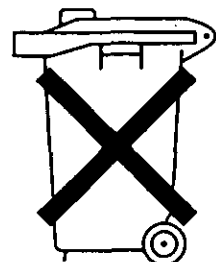

Specifications

[GENERAL]

Power supply:	DC12 V (10.5V to 17.0V)
Power consumption:	16W (main unit including viewfinder)

Operating ambient temperature:

32°F to 104°F (0°C to 40°C)

Storage ambient temperature:

-4°F to 140°F (-20°C to 60°C)

Operating ambient humidity:

Less than 80% (relative humidity)

Continuous operation time:

Approx. 120 minutes

(with Anton Bauer Trimpack 14, continuous recording time)

Dimensions

(W × H × D): 4-15/16" × 11-1/2" × 13-5/16" (126 × 292 × 337 mm)

Weight:

7.7 lbs (3.5 kg) for main unit only

13.0 lbs (5.9 kg) for with NP-1 battery, viewfinder, Fujinon 14× lens,
184-minute tape

[CAMERA]

Image sensor: 1/3" IT-type CCD with on-chip lens (pixel shift system) × 3

Pixels: 542 (H) × 492 (V)

Horizontal drive frequency:

11.25 MHz

Sensitivity: 2000 lux, f/5.6

Minimum illumination: 5 lux (f/1.4 +18 dB)

S/N ratio: 60 dB (TYP)

Horizontal resolution: Approx. 500 lines (center)

Vertical resolution: 400 lines

Sampling frequency: 13.5 MHz/27 MHz

Shutter speeds: 1/100, 1/125, 1/250, 1/500, 1/1000, 1/2000, 1/4000, 1/8000

Gain selection: 0/6/12 dB or 0/9/18 dB

Lens mount: 1/3" bayonet mount

Color separation optical system:

Prism system (f/1.4)

Registration error: Less than 0.03% (full range, excluding lens distortion)

ND filter: 1/16 ND, manual ON/OFF setting enabled by slide switch

[VIEWFINDER]

Display tube: 1.5" high-resolution monochrome tube

Horizontal resolution: 600 lines (center)

External controls: BRIGHT, CONTRAST, PEAKING controls,
TALLY ON/OFF, ZEBRA ON/OFF, CHARACTER ON/OFF switches

[VTR] The video and audio performance specifications apply for a tape which has been recorded on this unit and played back on a standard player (ANALOG COMPONENT OUT).

Tape speed: 33.8201 mm/sec
Recording/playback time: Approx. 184 min. (*using AJ-5P92LP)

* For AJ-5P92LP cassette tapes, use a VTR supporting DVCPRO (25 Mbps) 184 minute tapes.

FF/REW time: Less than 8 min. (using AJ-5P92LP)
Video signal band: Brightness = 0 Hz to 5.75 MHz, +1.0 dB/-3.0 dB
S/N ratio: 55 dB
Linearity: Less than 2%
Y/C delay: Within 30 ns
Audio sampling frequency: 48 kHz (synchronized with video)
Quantizing: 16 bits/sample
Frequency response: 20 Hz to 20 kHz, +1.0 dB/-1.5 dB (at reference level)
Distortion: Less than 0.2% (at 1 kHz, operating level)
Crosstalk: Less than -65 dB (between channels, at 1 kHz)
Wow and flutter: Below measurable limits
Headroom: 20 dB

[CONNECTORS]

INPUT FRONT MIC: Phantom +48V (built-in microphone), -60 dBu, balanced, 3 k Ω
(-60, -50 or -40 dBu setting possible on menu)
AUDIO IN CH1/CH2 (XLR, 3P):
-60, -50 or -40 dBu setting possible on menu, balanced, 10 k Ω
Internal DIP switch setting:
Phantom 48V output possible
line (-6/0/+4 dBu) switchable

OUTPUT AUDIO OUT CH1/CH2 (Phono pin jack):
-6 dBu, unbalanced, low impedance output
HEADPHONE OUT: Stereo mini jack
VIDEO OUT (BNC): 1.0 V_{P-P}, 75 Ω
S-VIDEO OUT: Y signal = 1.0 V_{P-P}, 75 Ω
C signal = 0.286 V_{P-P} (burst), 75 Ω

OTHER DC IN (XLR, 4P)
LENS (12P)
DVCPRO interface connector (option):
Complies with IEEE 1394-1995 standard

[ACCESSORIES]

1.5" viewfinder
Microphone (attached to main unit)
Battery holder (attached to main unit)
Battery mounting connector and screw supporting Sony-made battery (NP-1B)

SAFETY PRECAUTIONS

GENERAL GUIDELINES

1. When servicing, observe the original lead dress. If a short circuit is found, replace all parts which have been overheated or damaged by the short circuit.
2. After servicing, see to it that all the protective devices such as insulation barriers, insulation papers shields are properly installed.
3. After servicing make the following leakage current checks to prevent the customer from being exposed to shock hazards.

LEAKAGE CURRENT COLD CHECK

1. Unplug the AC cord and connect a jumper between the two prongs on the plug.
2. Measure the resistance value, with an ohm meter, between the jumpered AC plug and each exposed metallic cabinet part on the equipment such as screwheads, connectors, control shafts, etc. When the exposed metallic part has a return path to the chassis, the reading should be between $1M\Omega$ and $5.2M\Omega$. When the exposed metal does not have a return path to the chassis, the reading must be ∞ .

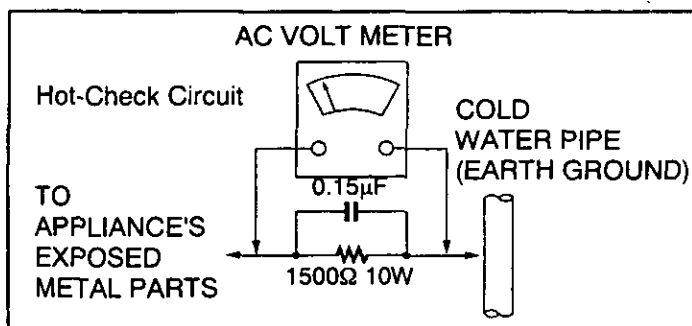

Figure 1

LEAKAGE CURRENT HOT CHECK (See Figure 1)

1. Plug the AC cord directly into the AC outlet. Do not use an isolation transformer for this check.
2. Connect a $1.5k\Omega$, 10W resistor, in parallel with $0.15\mu F$ capacitor, between each exposed metallic part on the set and a good earth ground such as a water pipe, as shown in Figure 1.
3. Use an AC voltmeter, with 1000 ohms/volt or more sensitivity, to measure the potential across the resistor.
4. Check each exposed metallic part, and measure the voltage at each point.
5. Reverse the AC plug in the AC outlet repeat each of the above measurements.
6. The potential at any point should not exceed 0.75 volts RMS. A leakage current tester (Simpson Model 229 equivalent) may be used to make the hot checks, leakage current must not exceed 1/2 millilamp. In case a measurement is outside of the limits specified, there is a possibility of a shock hazard, and the equipment should be repaired and rechecked before it is returned to the customer.

ELECTROSTATICALLY SENSITIVE (ES) DEVICES

Some semiconductor (solid state) devices can be damaged easily by static electricity. Such components commonly are called Electrostatically sensitive (ES) Devices. Examples of typical ES devices are integrated circuits and some field-effect transistors and semiconductor "chip" components. The following techniques should be used to help reduce the incidence of component damage caused by static electricity.

1. Immediately before handling any semiconductor component or semiconductor-equipped assembly, drain off any electrostatic charge on your body by touching a known earth ground. Alternatively, obtain and wear a commercially available discharging wrist strap device, which should be removed for potential shock reasons prior to applying power to the unit under test.
2. After removing an electrical assembly equipped with ES devices, place the assembly on a conductive surface such as aluminum foil, to prevent electrostatic charge buildup or exposure of the assembly.
3. Use only a grounded tip soldering iron to solder or unsolder ES devices.
4. Use only an anti-static solder removal device classified as "anti-static" can generate electrical charges sufficient to damage ES devices.
5. Do not use freon-propelled chemicals. These can generate electrical charges sufficient to damage ES devices.
6. Do not remove a replacement ES device from its protective package until immediately before you are ready to install it. (most replacement ES devices are packaged with leads electrically shorted together by conductive foam, aluminum foil or comparable conductive material).
7. Immediately before removing the protected material from the leads of replacement ES device, touch the protective material to the chassis or circuit assembly into which the device will be installed.
CAUTION: Be sure no power is applied to the chassis or circuit, and observe all other safety precautions.
8. Minimize bodily motions when handling unpackaged replacement ES devices. (Otherwise harmless motion such as the brushing together of your clothes fabric or the lifting of your foot from a carpeted floor can generate static electricity sufficient to damage an ES device).

X-RADIATION

WARNING

1. The potential source of X-Radiation in EVF sets is the High Voltage section and the picture tube.
2. When using a picture tube test jig for service, ensure that jig is capable of handling 10kV without causing X-Radiation.
NOTE: It is important to use an accurate periodically calibrated high voltage meter.
3. Measure the High Voltage. The meter (electric type) reading should indicate 2.5kV, $\pm 0.15kV$. If the meter indication is out of tolerance, immediate service and correction is required to prevent the possibility of premature component failure. To prevent an X-Radiation possibility, it is essential to use the specified picture tube.

Precautions for Use

1. Vibration

Avoid using this product in any location where it will be subjected to a great deal of vibration.

2. Ambient operating temperature

This product is designed to operate across a temperature range of 32°F to 104°F (0°C to +40°C). Adequate care should be taken when the product is operated outside this range since it may develop differences in interchangeability or it may not function properly, and its active service life will be shortened.

3. Rain, humidity and dust

Minimize operation in the rain or when the humidity level is high since condensation will form inside the product, thereby causing failures. Take care when using the product in very dusty locations since dust will find its way inside the product which, in particular, will cause a deterioration in its characteristics.

4. Sunlight

Do not point the lens in the camera section at the sun with the iris open. Neither should the viewfinder's eyepiece be pointed at the sun. Failure to heed this warning may cause malfunctioning inside the product.

5. Handling

Do not drop the product or subject it to impact. Failure to heed this warning will cause malfunctioning. Also, do not poke objects inside the product while the cassette cover is in the raised position.

6. Strong electrical and magnetic fields

Bear in mind that using this product in an extremely strong electrical or magnetic field may result in interference with the picture on the screen or with the sound.

Features

Compact and lightweight integrated camera/VTR unit with low power consumption

Camera with high picture quality

- Digital processing ensures that the high picture quality remains stable during prolonged use.
- A time code reader/generator is built into the unit.
- 1/3-inch interchangeable lenses are featured to enable top-quality operation.
- Use of the built-in ND filter makes it possible to obtain the proper aperture even when shooting in outdoor locations.

Other features

- The on-screen menu setting facility makes it easy to set a large number of functions.
- Installation of optional digital video interface board (AJ-YAD210P: DVCPRO Terminal <complies with IEEE 1394-1995 standard>) supported.
- Long-time recording possible up to a full 184 minutes. (using AJ-5P92LP*)

* For AJ-5P92LP cassette tapes, use a VTR supporting DVCPRO (25 Mbps) 184 minute tapes.

- Dolby noise reduction manufactured under license from Dolby Laboratories Licensing Corporation.
- "DOLBY" and the double-D symbol  are trademarks of Dolby Laboratories Licensing Corporation.

CAUTION

This camera/VTR product supports "L" size DVCPRO tapes only.
Do not use consumer DV tapes or tapes of any other size.

System chart

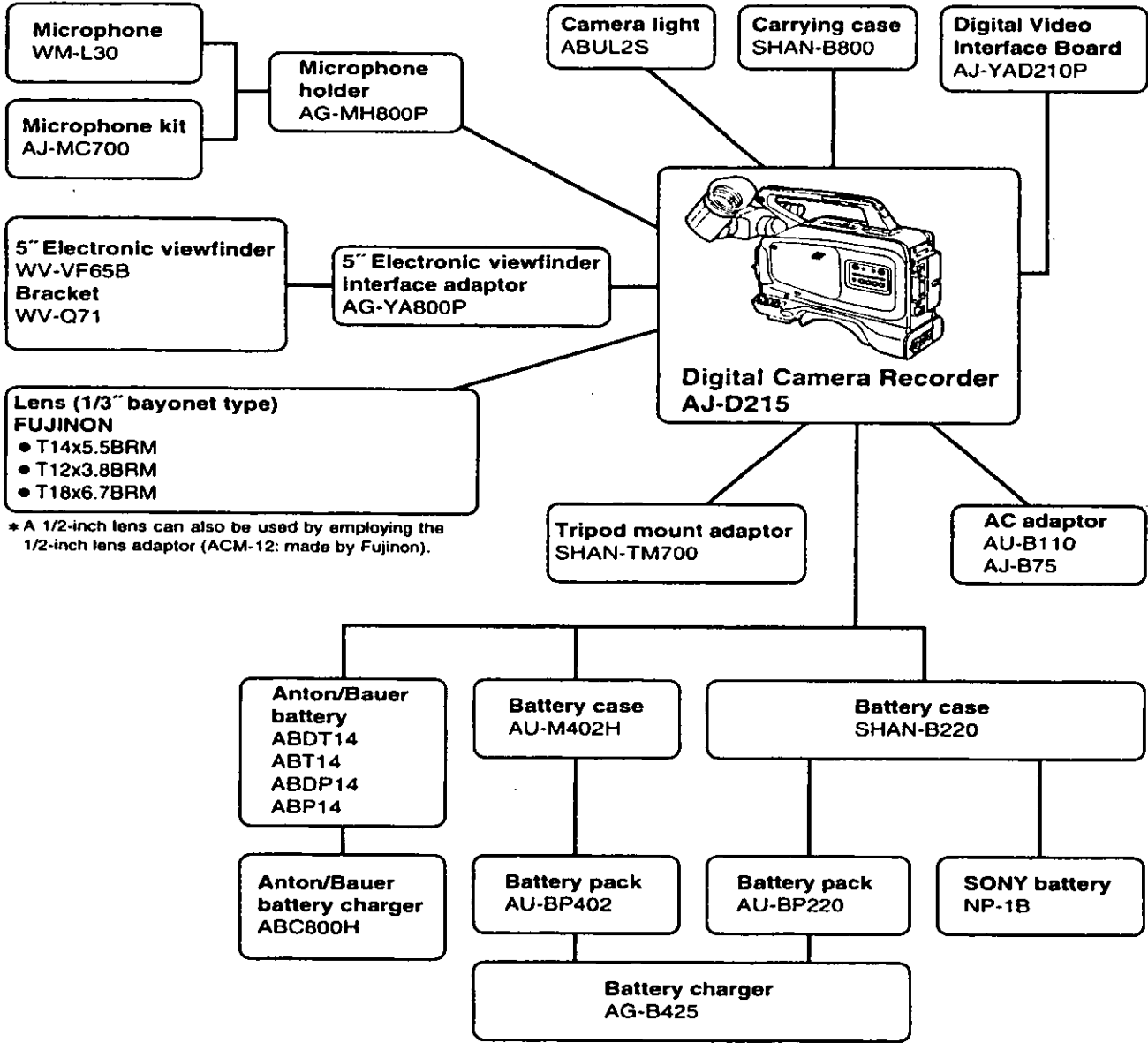

Parts and their functions

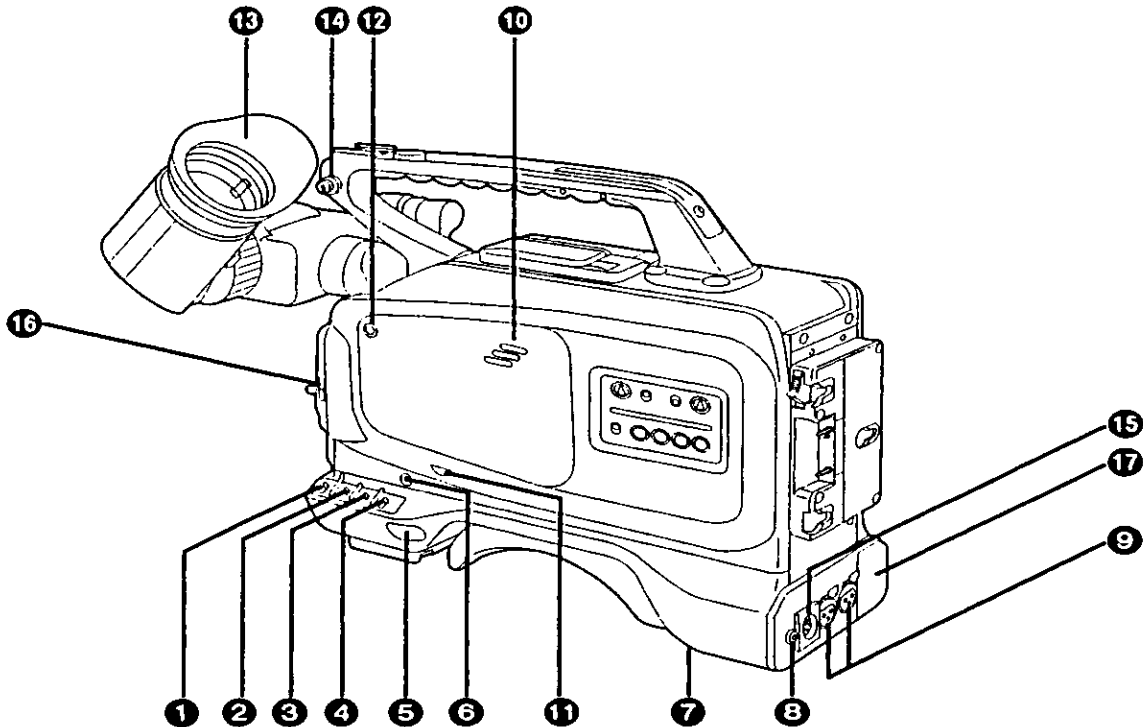

1 GAIN selector switch

When the camera picture is too dark, increase the gain to brighten the picture by setting this switch.

0dB: The switch is normally kept at this position.

6/9dB: The gain of the camera's video amplifier is increased at this position. Select 6 dB or 9 dB on the on-screen menu first. For further details, refer to the menu items (on pages 48, 49 and 53).

12/18dB: The gain of the camera's video amplifier is increased at this position. Select 12 dB or 18 dB on the on-screen menu first. For further details, refer to the menu items (on pages 48, 49 and 53).

The amount of noise also increases when the gain is increased.

2 White balance selector switch

MEMO: When the AUTO W/B (WHITE/BLACK) BAL switch on the front panel is operated, the white balance is adjusted automatically, and the adjustment value is stored in the internal memory.

PRST: Although the preset mode was set to INDOOR when the unit was shipped from the manufacturing plant, there is a choice between three settings altogether on the on-screen menu. For further details, refer to the menu items (on pages 48, 49 and 53).

OUTDOOR 5000K	INDOOR 3200K	FLUOR 4500K
------------------	-----------------	----------------

ATW: This is the automatic tracking white balance mode.

Note:

It may not be possible to attain the correct white balance under some types of lighting .

3 OUTPUT selector switch

CAM: The video signals shot by the camera are output.

BAR: The color bar signals are output.

<Note>

Shown in the figure below are the output levels which are shown as color bar signals by this unit.

It should be noted that these are not SMPTE color bars.

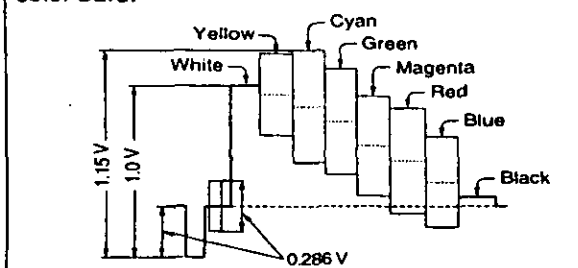

4 SHUTTER switch

This is the ON/OFF selector switch of the electronic shutter.

OFF: The electronic shutter does not work at this position.

ON: The electronic shutter is operational at this position.

SELECT: This position is used to change the speed of the electronic shutter. This is a non-locking switch. Each time it is operated, the shutter speed changes by one setting in the following sequence: 1/100 → 1/125 → 1/250 → 1/500 → 1/1000 → 1/2000 → 1/4000 → 1/8000. When the switch is operated at 1/8000, the speed returns to the 1/100 setting.

5 POWER switch

ON: All the functions of the camera VTR are made operational.

OFF: The power to the camera VTR is turned off.

6 MODE CHECK switch

This enables the settings of the camera's function switches to be checked in the viewfinder.

7 BREAKER switch

If trouble causes an excessively high current to flow inside the unit, the circuit breaker is tripped, causing the power to be turned off automatically to protect the unit.

Upon completion of inspection inside or repair work on the unit, push this button to the "in" position. The power will be turned on again provided that no trouble has occurred.

8 Earphone (PHONE) jack

This is the earphone (stereo) jack for monitoring the sound. When an earphone is connected, no sound will be heard from the speaker.

9 Audio input connectors

External microphones are connected here. Line input signals can also be connected by setting an internal switch to the corresponding position.

10 Speaker

The sound can be monitored through this speaker.

- The sound from the speaker is automatically cut off when an earphone is connected to the PHONE jack.

- The CH1 and CH2 sound is mixed and heard as the monitored sound.

11 Audio monitor level control

This volume control is used to adjust the sound when it is being monitored.

12 MARK/CANCEL button

This is the SCENE data function switch. For further details, refer to the SCENE data function section (on pages 56 and 57).

13 Viewfinder

14 Shoulder belt fitting

The shoulder belt is fastened here.

15 External DC input socket

This socket is for the external power (DC) supply. Connect an AC adaptor.

When the adaptor is connected, power is automatically supplied from the external power source.

16 ND filter ON/OFF switch

OFF: The ND filter is not used.

ON: The ND filter is used.

17 DVCPRO interface connector installation area (option)

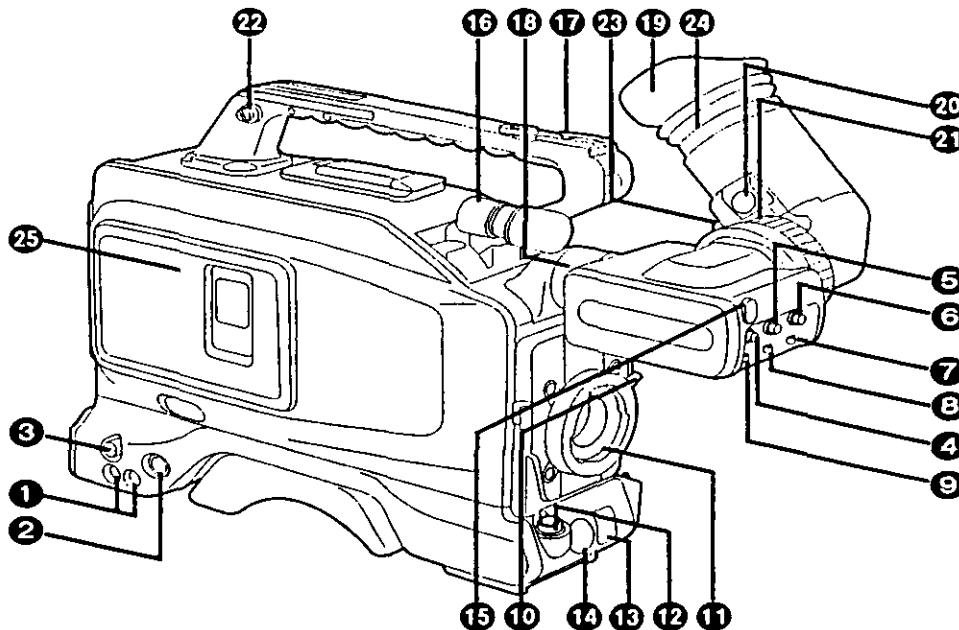

1 AUDIO OUT connectors (pin jacks)

2 S-VIDEO OUT connector (Y/C connector)

CAUTION:

Bear in mind that if any action that involves playing back a tape on this VTR (such as REC CHECK or retake) is taken while a back-up VTR is connected to the S-VIDEO OUT connector to record pictures, the pictures played back by this unit will be recorded on the back-up VTR.

3 VIDEO OUT connector (BNC)

CAUTION:

Bear in mind that if any action that involves playing back a tape on this VTR (such as REC CHECK or retake) is taken while a back-up VTR is connected to the VIDEO OUT connector to record pictures, the pictures played back by this unit will be recorded on the back-up VTR.

4 PEAKING control

Turning this control sharpens the outlines of the images in the viewfinder to facilitate focusing. The control has no effect on the camera's output signals.

5 CONTRAST control

This is used to adjust the contrast of the images in the viewfinder. It has no effect on the camera's output signals.

6 BRIGHT (brightness) control

This is used to adjust the brightness of the images in the viewfinder. The images become brighter when it is turned clockwise. It has no effect on the camera's output signals.

7 TALLY ON/OFF switch

ON: The tally lamp on the front of the viewfinder lights.
OFF: The tally lamp on the front of the viewfinder does not light.

8 ZEBRA (zebra pattern) ON/OFF switch

ON: A zebra pattern is displayed in the viewfinder.
OFF: A zebra pattern is not displayed.

9 CHARACTER ON/OFF switch

This turns the character display ON or OFF.
ON: Characters are displayed in the viewfinder.
OFF: Characters are not displayed in the viewfinder.

The color temperature display in the ATW mode and the SCENE data MARK will appear even when the CHARACTER ON/OFF switch is at the OFF position.

-
-
- 10 Lens locking lever**
After the lens has been attached to the lens mount, this lever is tightened up to lock the lens in position.
- 11 Lens mount (bayonet type)**
This attaches the lens.
- 12 LENS connector (12-pin)**
The connecting cord of the lens is connected here. For a detailed description of the lens to be used, read the instruction manual which accompanies the lens.
- 13 AUTO W/B (WHITE/BLACK) BAL switch**
AWB: The white balance and black balance are automatically adjusted. When the white balance selector switch is set to the MEMO position and then the AUTO W/B BAL switch is operated, the adjustment value is stored in the unit's memory. Bear in mind that no operation results when the selector switch is set to the ATW or PRST position.
- 14 VTR START/STOP button**
This is used to start or stop the recording.
- 15 TALLY lamp**
This lights when the image shot by the camera is being recorded by the VTR. It lights or flashes in tandem with the TALLY lamp inside the viewfinder.
- 16 Microphone**
This is a compact unidirectional microphone. A microphone with sharp directionality can be attached by replacing the microphone provided with the optional holder.
- 17 Accessory hole**
A video light or other accessory is installed here.
- 18 Viewfinder locking ring**
This is used to attach or remove the viewfinder. When the ring is loosened, the viewfinder can be rotated by 90 degrees and pointed upward.
- 19 Eye cup**
- 20 Eye cup unlocking lever**
This is used to remove the eye cup. The eye cup is removed by moving the lever in the direction of the arrow and then sliding the eye cup free.
- 21 Viewfinder locking stopper**
This is used to adjust the viewfinder's position. To adjust the position, loosen the stopper and move the viewfinder to the left or right. After having adjusted the position, tighten up the stopper to lock the viewfinder in place.
- 22 Shoulder belt fitting**
The shoulder belt is fastened here.
- 23 Diopter control (bottom panel)**
Adjust this to match your eyesight so that you can clearly see the images inside the viewfinder.
- 24 Eyepiece position adjustment ring**
This enables the eyepiece position to be adjusted forward or backward when used in the unlocked status. Upon completion of the adjustment, set it to the LOCK status to lock the eyepiece in position.
- 25 Cassette holder**
This is the slot where the cassette tape is loaded.

Function buttons

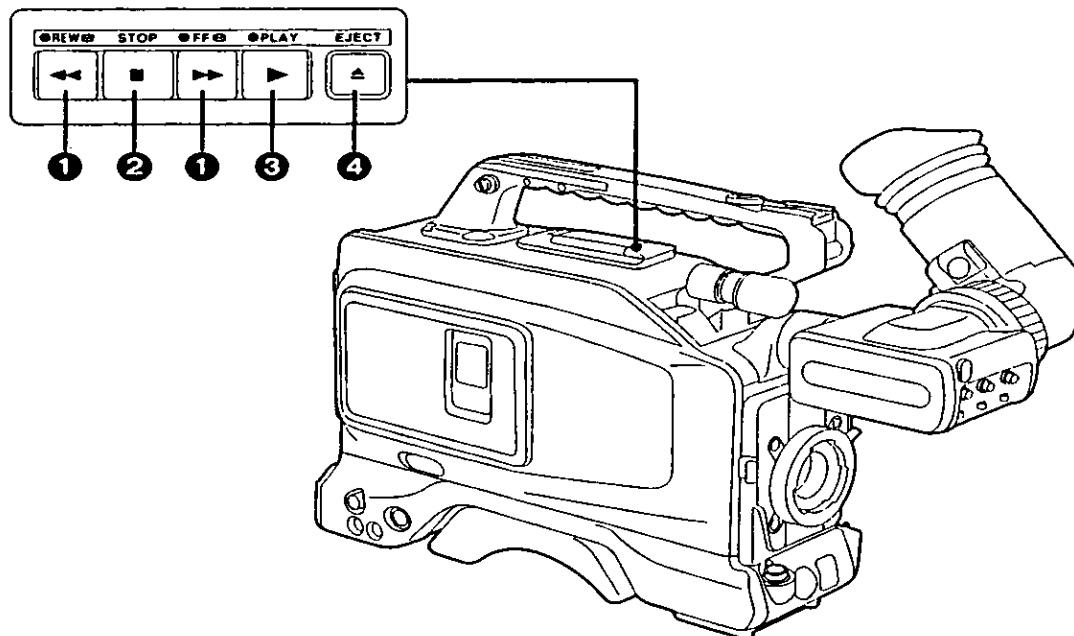

① REW (rewind)/FF (fast forward) buttons

- When the REW or FF button is pressed while the tape has stopped traveling, the tape is rewound or fast forwarded at the normal rewinding or fast forwarding speed in the E-E mode.
- When the REW or FF button is pressed while the tape is being played, the tape is reviewed or cued at approximately 4.5 times the normal tape speed.
- When the REW or FF button is pressed in the STILL or REC PAUSE mode, the tape is reviewed or cued at approximately 1 times the normal tape speed.

② STOP button

The tape stops traveling when this button is pressed. The button does not work during recording. To stop the tape during recording, first establish the REC/PAUSE mode and then press the STOP button.

③ PLAY button/lamp

When this button is pressed, play is commenced and its lamp lights. When it is pressed again, the STILL mode is established, and when it is pressed once more, the PLAY mode is established again.

④ EJECT button

When this button is pressed, the cassette holder rises, and the cassette tape can be loaded or removed. The button does not work when the VTR is in the REC mode. To eject a tape in the REC mode, first establish the REC/PAUSE mode and then press the EJECT button.

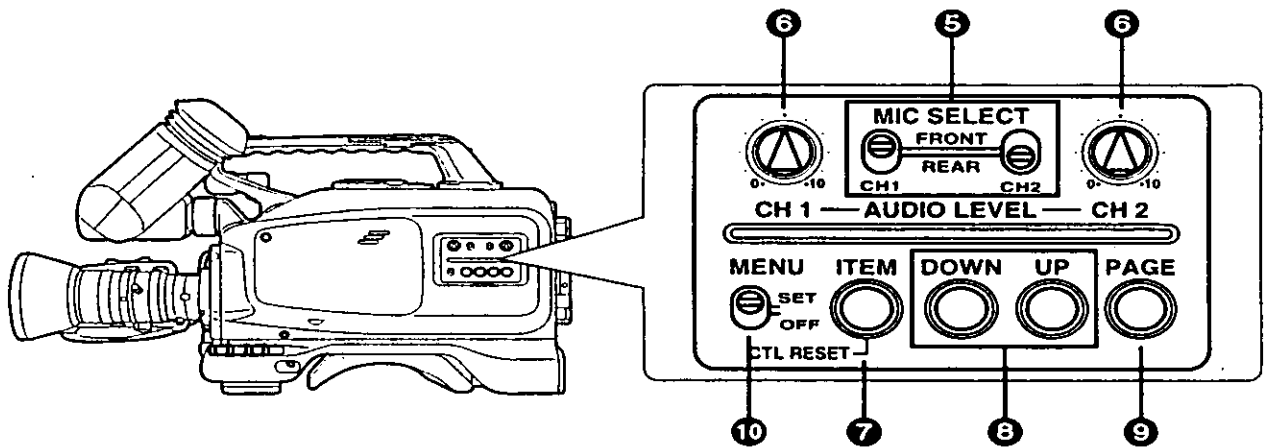

- 5 Audio input selector (MIC SELECT) switches**
 These switches are used to select the CH1 and CH2 audio input.
FRONT: Set to this position when recording audio signals from the microphone incorporated in the camera.
REAR: Set to this position when connecting external microphones to the audio input connectors (XLR 3P) on the rear panel and recording the audio signals from these microphones.

- 6 Audio level controls**
 These are used to adjust the CH1 and CH2 recording levels.

- 7 ITEM button**
 This is used to select menu items. When the **10** MENU switch is at OFF, it functions as the reset button for the CTL counter.
- 8 DOWN and UP buttons**
 These are used to make changes to the menu settings.
- 9 PAGE button**
 This is used to set the menu items.
- 10 MENU SET/OFF selector switch**
SET: Set to this position when displaying or making changes to menu items.
OFF: The switch is normally kept at this position.

14× Power Zoom Lens (option)

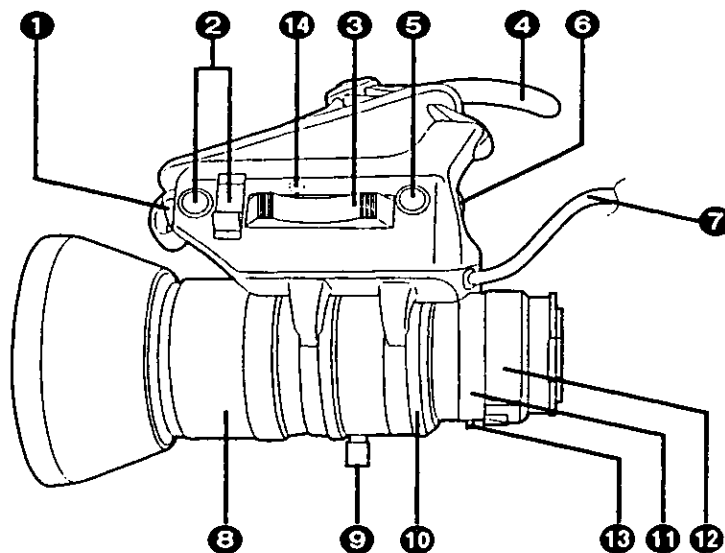

1 Automatic iris control

This enables the automatic iris speed to be adjusted.

Removal of the rubber cap reveals the control inside. The speed is increasing by turning the control clockwise but take care not to turn it too far since hunting (continuous cycling) will occur.

This control must be adjusted when the lens has been replaced or when a lens has been mounted for the first time.

2 Lens iris selector switch (IRIS)

(A) side: The iris is adjusted automatically.

(M) side: Set to this position to adjust the iris manually.

3 Power zoom control switch

The zoom can be controlled electrically by setting the power/manual zoom selector switch to SERVO and then pressing the power zoom control switch. The zoom speed differs depending on the force with which the switch is pressed.

4 Hand strap

Adjust this to fit the size of your hand.

5 Return switch (RET, REC CHECK)

This switch is for checking a recording. When it is pressed in the recording pause mode, the recording check function is activated, the recorded section is played back, and then the recording is placed in the pause mode.

6 VTR start/stop switch

This switch provides easy manual access to starting and stopping the VTR recording. When it is pressed once, recording starts; when it is pressed again, it stops. When using this lens, the VTR can be controlled by this switch or the VTR start/stop switch on the camera.

7 Lens cable (12-pin)

This cable is to be connected to the LENS connector.

8 Focus ring

This ring is turned to focus the lens.

9 Zoom ring

To adjust the screen size, set the power/manual zoom selector switch to MANU, and turn this ring.

-
-
- 10 Iris ring**
To adjust the iris, set the lens iris selector switch (IRIS) to M, and turn this ring.
 - 11 Flange back adjustment ring**
To adjust the flange back, loosen the flange back locking knob, and turn this ring. The ring must be adjusted when the lens has been replaced or when a lens has been mounted for the first time.
 - 12 Macro ring**
To take close-ups, set the lens all the way to the wide position, and turn this ring.
 - 13 Flange back locking knob**
Use this knob to lock the flange back after it has been adjusted.
 - 14 Power/manual zoom selector switch**
When this switch is set to SERVO, the zoom can be adjusted using the power zoom control switch. When it is set to MANU, the zoom can be adjusted using the zoom ring.

Also refer to the operating instructions accompanying the lens you have purchased.

Viewfinder displays

LED displays

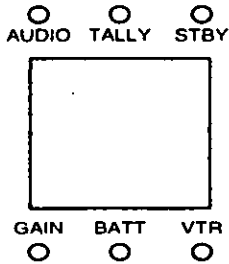

AUDIO (yellow): This is not used in this system.

TALLY (red): This lights during recording. It flashes as the tape is approaching the recording position from unloading or when trouble has occurred.

STBY (green): This is not used in this system.

GAIN (yellow): This lights when the camera gain is increased.

BATT (yellow): This flashes when the battery charge has dropped.

VTR (yellow): This lights or flashes when trouble has occurred in the VTR.

Character displays

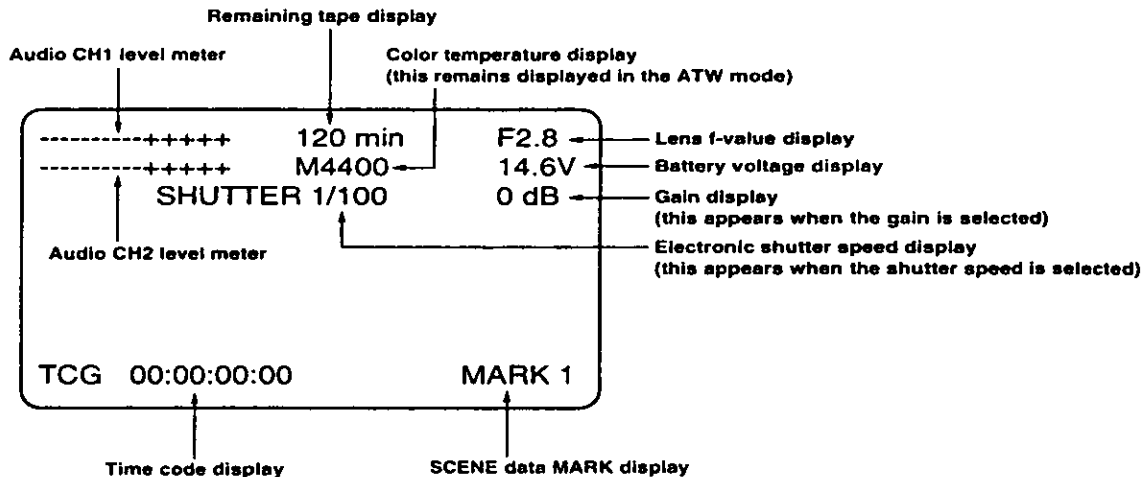

- These displays appear when the CHARACTER switch at the front of the viewfinder is set to ON.
- Each individual display can be turned off by setting the corresponding menu item.
- When the mode check switch has been pressed, the current statuses are displayed regardless of whether the individual displays have been set ON or OFF using the corresponding menu items or whether the CHARACTER switch is ON or OFF.
- The color temperature display in the ATW mode and the SCENE data MARK will appear even when the CHARACTER ON/OFF switch is at the OFF position.

Error message displays

When an error occurs, an error message appears in the viewfinder.

There are two types of error messages: those which appear when the power is switched on, and those which appear during operation.

The tables given below indicate the causes and remedial action for the corresponding error messages.

Error messages which appear when the power is switched on

Error display	Cause	Remedial action
BACKUP BATTERY EMPTY	This appears when the internal clock battery has run down. Remarks: A flat back-up battery will interfere with the clock and time code free run functions although all other functions will remain unaffected. Replace the back-up battery at the earliest possible opportunity. The BACKUP BATTERY EMPTY display will appear even when the power is turned back on immediately after the back-up battery was replaced. This is normal and not indicative of a malfunction.	Replace the unit's back-up battery. For the replacement procedure, refer to page 58, and consult with your dealer.
FLASH MEMORY EMPTY	This appears when garbage data in the built-in flash memory needs to be collected. A special memory called a flash memory is used inside this unit. It contains all the menu settings, white balance adjustment data and many other types of data. Due to the fact that this is a special memory, the old data no longer required when menu changes are made, for instance, are retained. Consequently, garbage memory contents such as these must be collected from time to time. Remarks: This display appears well ahead of time so there is no need to panic and initiate garbage collection immediately. The garbage collection processing takes some time (about 1 minute) so it should be done when there is a spare moment.	Proceed with garbage collection on the MAINTENANCE menu screen among the menu items. Refer to the menu items (on pages 48, 49 and 55).

Error messages which appear during operation

Error display	Cause	Remedial action
TOO BRIGHT ERROR	This appears when the white balance is to be adjusted (when the AUTO W/B BAL switch was operated) or when the screen is excessively bright.	Stop down the iris a little more, and adjust the white balance. If the error display remains, insert the electronic shutter or attach the ND filter.
TOO DARK ERROR	This appears when the white balance is to be adjusted (when the AUTO W/B BAL switch was operated) or when the screen is excessively dark.	Open the iris a little more, increase the gain (if this is warranted by the subject brightness), and adjust the white balance. If the error display remains, direct some light onto the subject.
LENS UNIT ERROR	This appears when the lens cable has been disconnected or when the lens iris control circuit has been damaged.	The cause is almost always a disconnected lens cable. If the display appears even when the cable is connected properly, consult with your dealer.
SELECT SW ERROR	This appears when the AUTO W/B BAL switch was operated with the white balance selector switch at a position other than MEMO.	Adjust the white balance (operate the AUTO W/B BAL switch) with the white balance selector switch at the MEMO position.
OUTPUT SW ERROR	This appears when the AUTO W/B BAL switch was operated with the OUTPUT switch at a position other than CAM.	Adjust the white balance (operate the AUTO W/B BAL switch) with the OUTPUT switch at the CAM position.
BLACK BAL ERROR	This points to a malfunction in the camera unit.	Consult with your dealer.
WHITE BAL ERROR TRY AGAIN	This appears when the white balance was not attained properly due to some condition or other.	If the TOOL BRIGHT ERROR, TOO DARK ERROR or LENS UNIT ERROR message has appeared, take the corresponding measure, and then try adjusting the white balance again. If the WHITE BAL ERROR TRY AGAIN message has appeared but the TOOL BRIGHT ERROR, TOO DARK ERROR or LENS UNIT ERROR message has not appeared, proceed to attain the white balance again. If the display still appears even after two or three attempts, consult with your dealer.
<p>Remarks: The above errors are detected when the white balance is adjusted (when the AUTO W/B BAL switch has been operated). The LENS UNIT ERROR is also detected immediately after the power has been switched on.</p>		
SERVO	This appears when an unrecorded part of a tape is played back or at other times when the VTR servo lock is disengaged.	It is normal for this display to appear with unrecorded parts of tapes. If the display appears during the playback of an obviously recorded tape or during recording, this points to a malfunction. Consult with your dealer.
HUMID	This signifies that condensation has formed. Refer to page 63 where detailed instructions can be found.	Refer to page 63 where detailed instructions can be found.
POWER OFF	This is not an error message. It is a warning which indicates that the power will be turned off very shortly.	

Preparations

■ Attaching the peripheral units

Attaching the lens

- 1** Position the lens, insert it, and lock it in place using the lens locking lever.

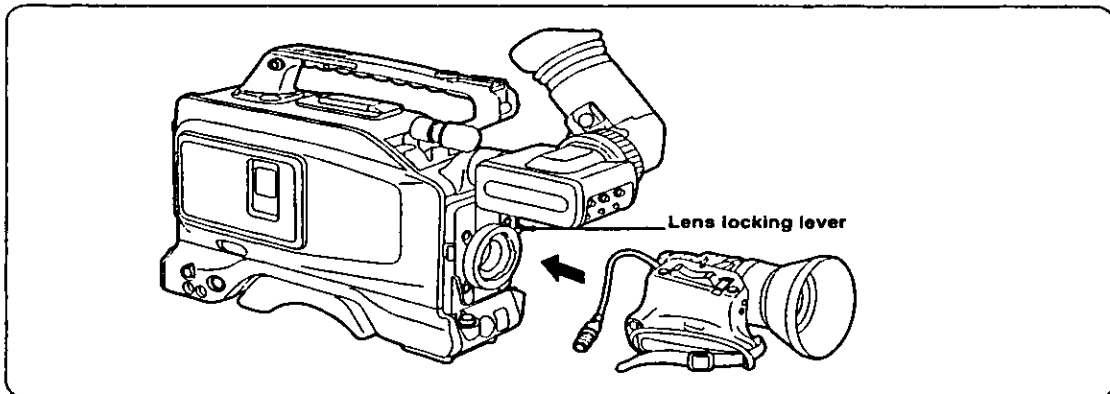

- 2** Connect the cord to the LENS connector, and secure it using the cable clamp.

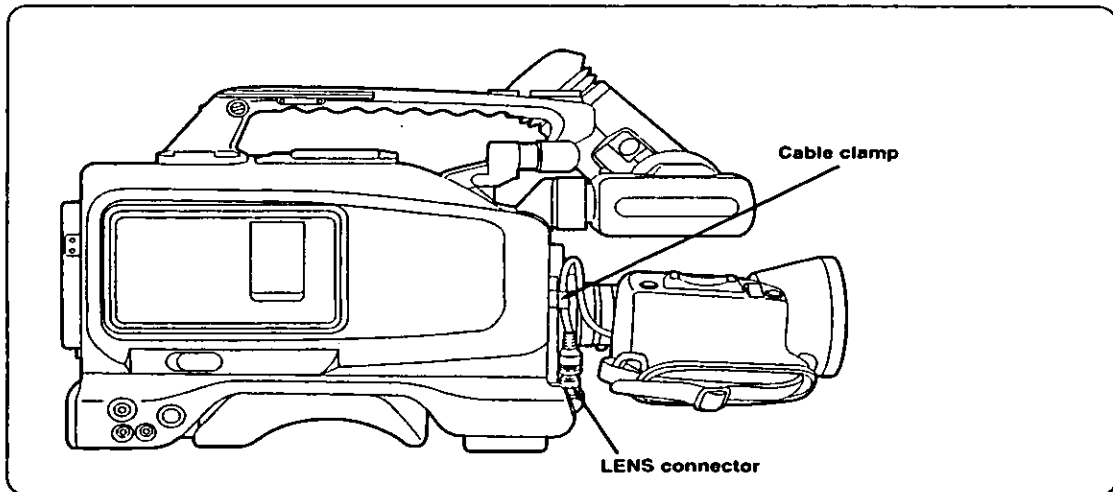

- Notes:**
- Refer to the operating instructions accompanying the lens for details on handling the lens.
 - Attach the lens cap to protect the unit when the lens has been removed.

Mounting the viewfinder

1 Align the positions of the marks (red), and fit into place.

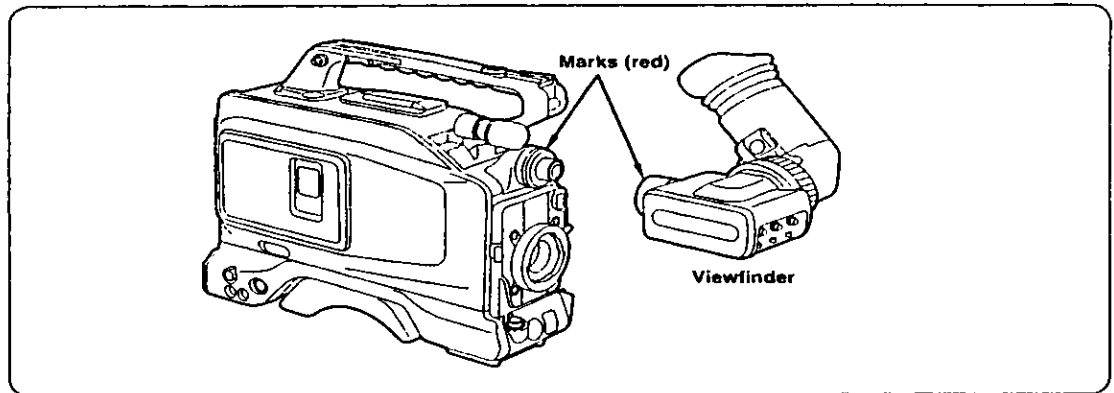

2 Turn the viewfinder locking ring to lock the viewfinder into place.

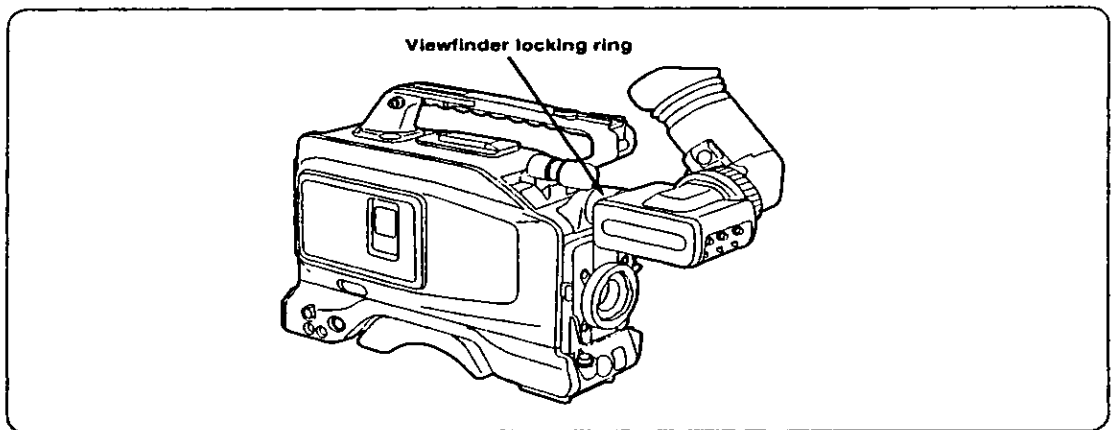

The viewfinder can be turned by 90 degrees by loosening the locking ring.

Removing the eye cup

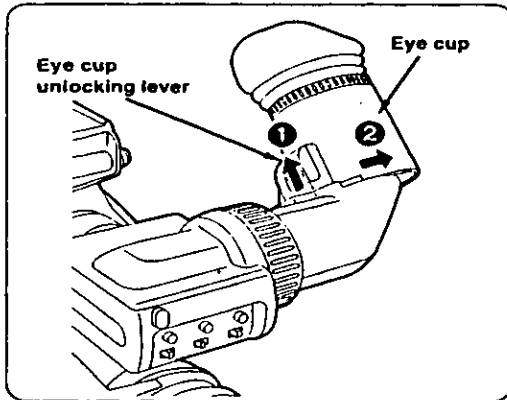

- 1 Move the eye cup unlocking lever in the direction indicated by the arrow.
- 2 Slide the eye cup in the direction indicated to remove it.

Adjusting the eyepiece position

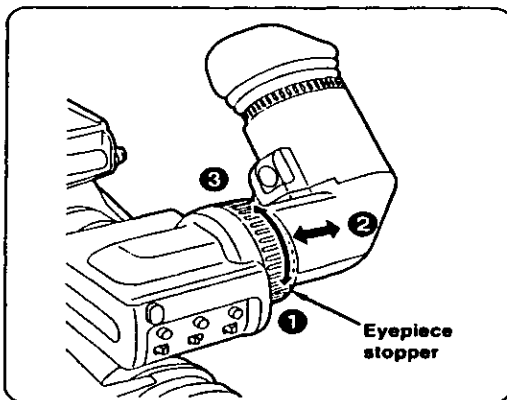

- 1 Set the eyepiece stopper to FREE.
- 2 Move the eyepiece toward the left or right to a position which affords the easiest viewing.
- 3 Tighten the eyepiece stopper.

Adjusting the eye cup position

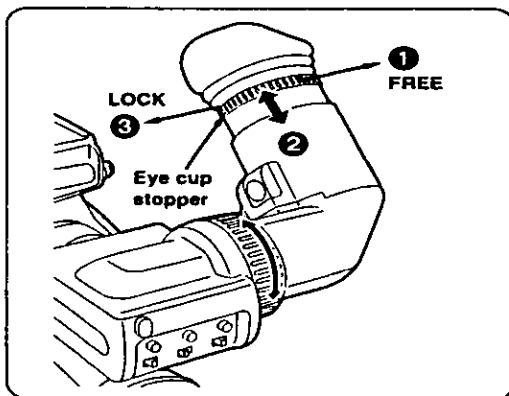

- 1 Set the eye cup stopper to FREE.
- 2 Adjust the eye cup by moving it toward you or away from you.
- 3 Set the eye cup stopper to LOCK to lock the eye cup in place.

When using a battery pack made by Anton/Bauer

Before using the battery pack, charge it using the special battery charger made by Anton/Bauer. For the charging time and other details, refer to the operating instructions of the battery charger used.

1 Attach the battery pack made by Anton/Bauer.

Insert it in the direction indicated by the arrow and slide it into place.

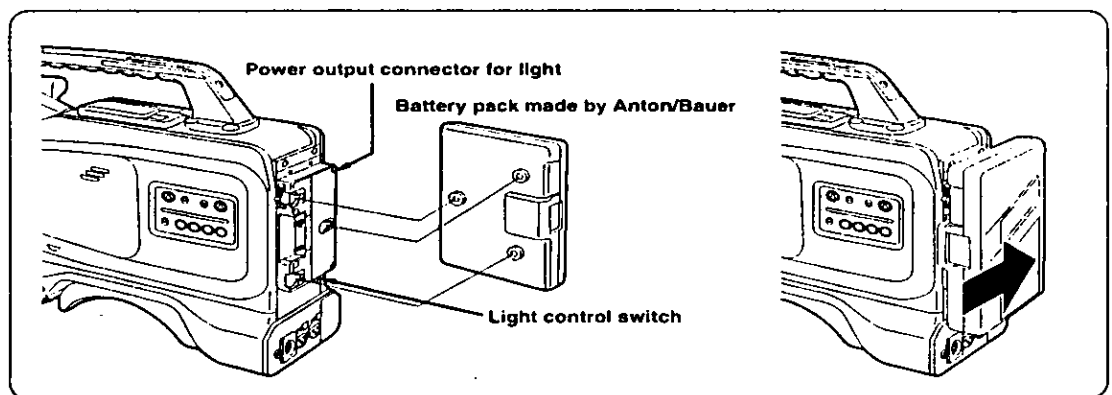

■ Provided on the battery holder made by Anton/Bauer are a power output connector for a light and a light control switch. A light can be easily attached. For details on lighting systems, consult an Anton/Bauer representative.

2 Set menu item 7. BATTERY (BATT.SELECT) to the battery which is to be used.

For further details, refer to the menu items (pages 48 to 50).

Remarks: ■ **To remove the battery pack**

While holding the unlocking lever on the battery holder all the way down, slide the battery pack in the direction indicated by the arrow.

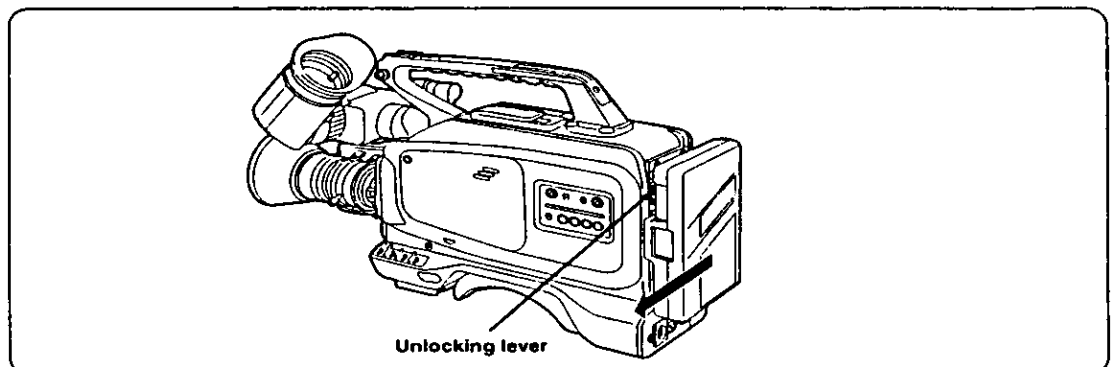

When using the AU-BP402 battery pack

Charge the AU-BP402 battery pack using the AG-B425 battery charger. It takes about an hour to charge the battery pack. For further details, refer to the operating instructions accompanying the AG-B425 battery charger.

1 Remove the battery holder.

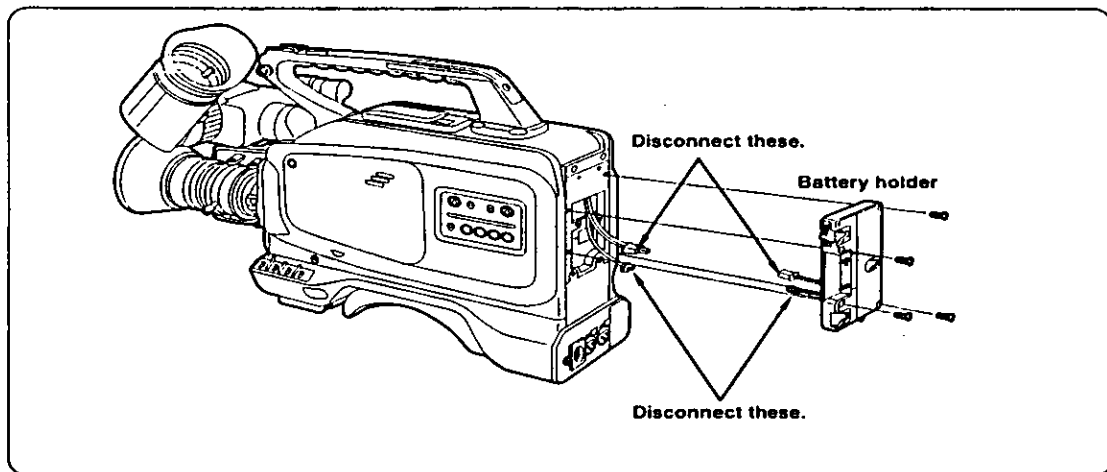

2 Connect the unit's cables to the AU-M402H battery case cables.

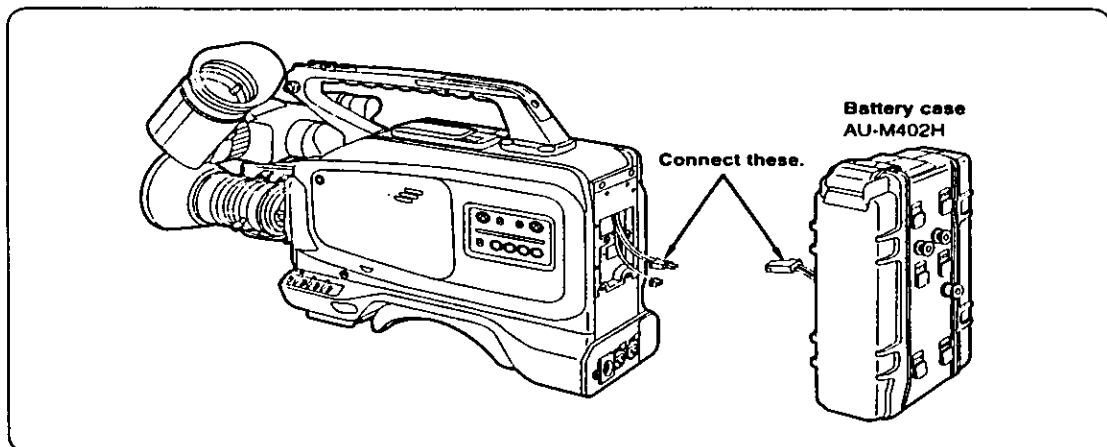

3 Mount the AU-M402H battery case onto the unit using a screwdriver.

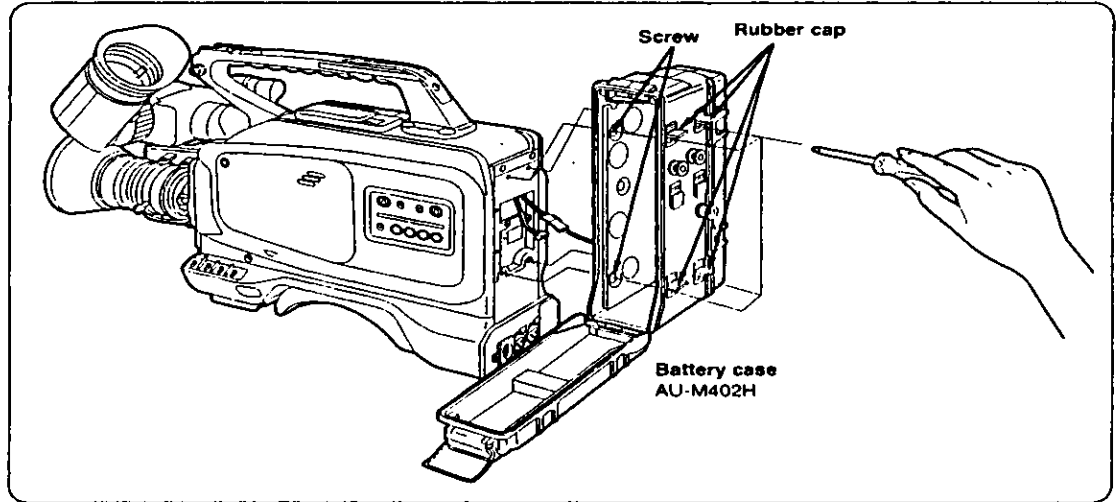

Holes with the screws recessed inside can be seen when the cover is opened and the rubber caps are lifted. Tighten up these screws using a screwdriver so that the battery case is mounted onto the unit. Tighten the screws up all the way.

CAUTION: Do not pull the rubber caps with too much force.

4 Connect the plug of the battery pack to the connector inside the battery case, and install the battery pack inside the case.

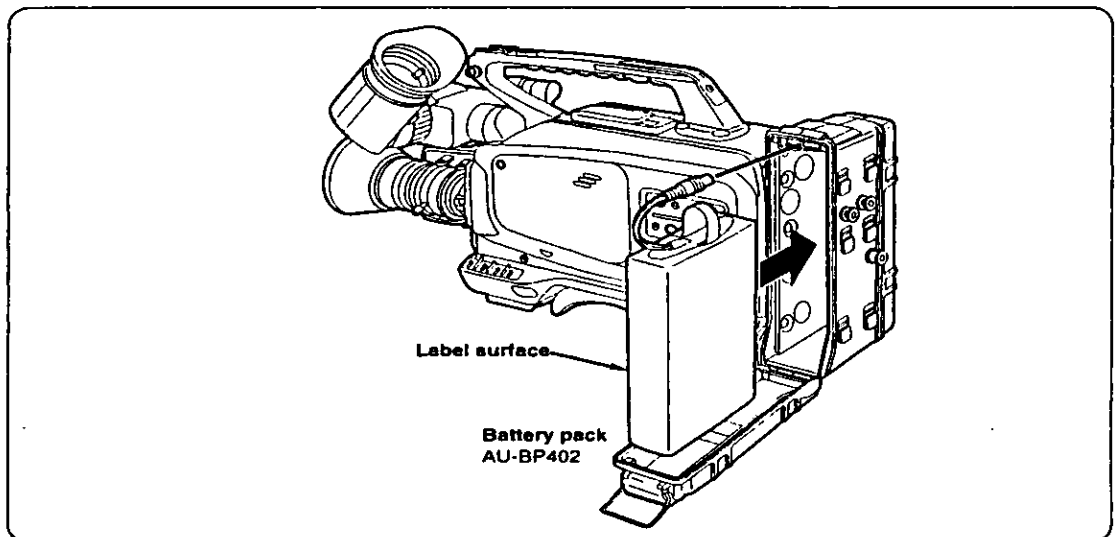

CAUTION: The unit's power must be turned off before the plug is connected or disconnected.

5 Set menu item 7. BATTERY (BATT.SELECT) to NiCd12V.

Menu item screen (viewfinder)

- MAIN FUNCTION -	
TCG CLEAR	
RECRUN/FREERUN	: REC
DF/NDF	: DF
SCENE DATA SAVE	
SCENE DATA UNDEL	
- BATT. SELECT	: NiCd12
BACK TALLY	: ON
MENU INITIALIZE	

For further details, refer to the menu items (pages 48 to 50).

When using the NP-1B battery made by Sony

Charge the NP-1B battery using the special battery charger made by Sony.
For the charging time and other details, refer to the operating instructions accompanying the battery charger used.

1 Remove the battery holder.

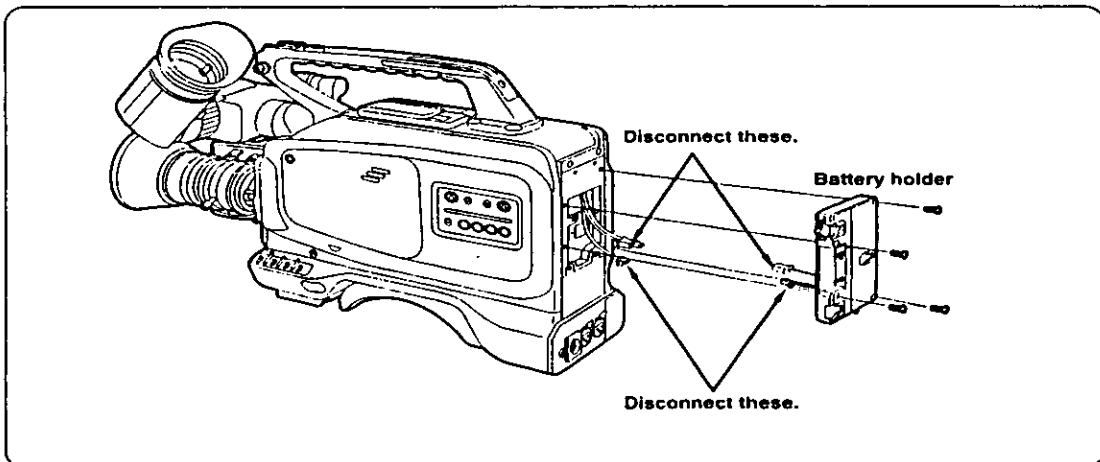

2 Attach the accessory NP-1B mounting connector.

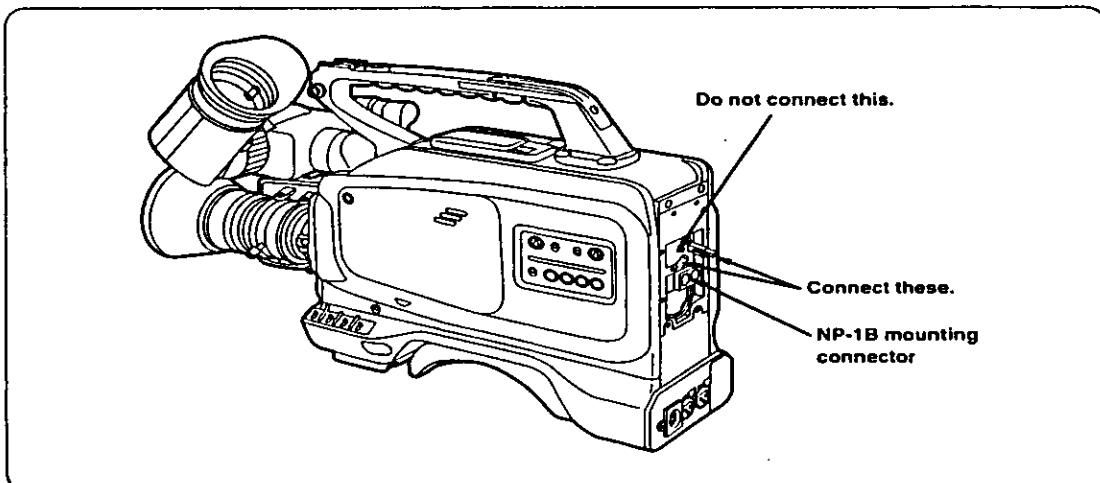

3 Mount the battery holder made by Sony

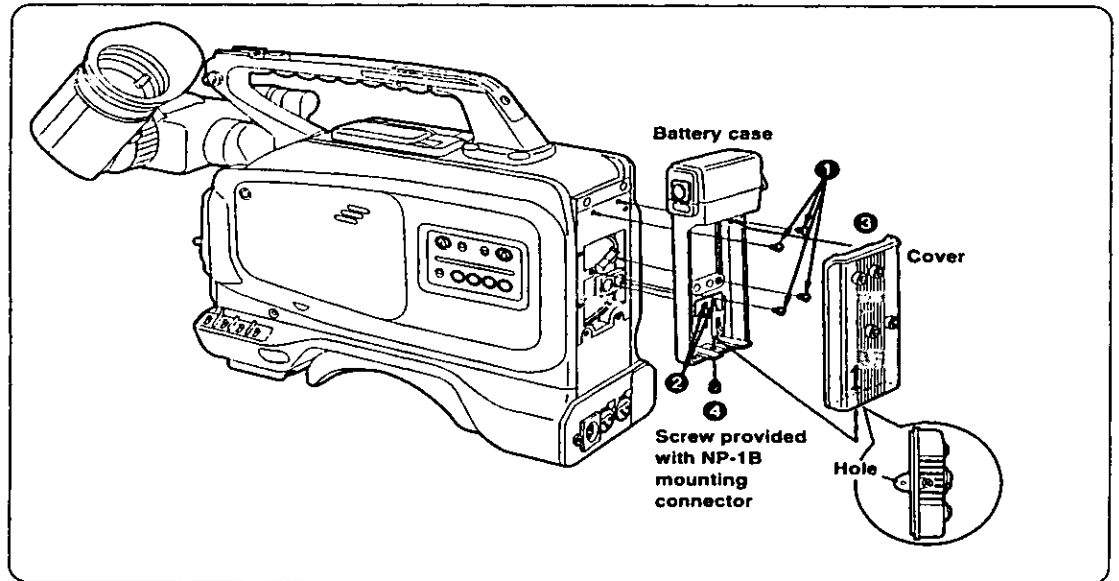

Before proceeding any further, remove the battery holder cover.

- ① Mount the battery case using the mounting screws.
- ② Tighten the power contact screw.
- ③ Insert the top of the cover in the direction indicated by the arrow.
- ④ Align the hole at the bottom (metal part) of the cover with the hole at the bottom of the battery case and mount the battery holder using the screw provided with the NP-1B mounting connector.

**When using an AC power source
(when using the AU-B110/AJ-B75 AC adaptor)**

- 1** Connect the unit's external DC input socket to the DC OUT connector on the AU-B110/AJ-B75 AC adaptor.

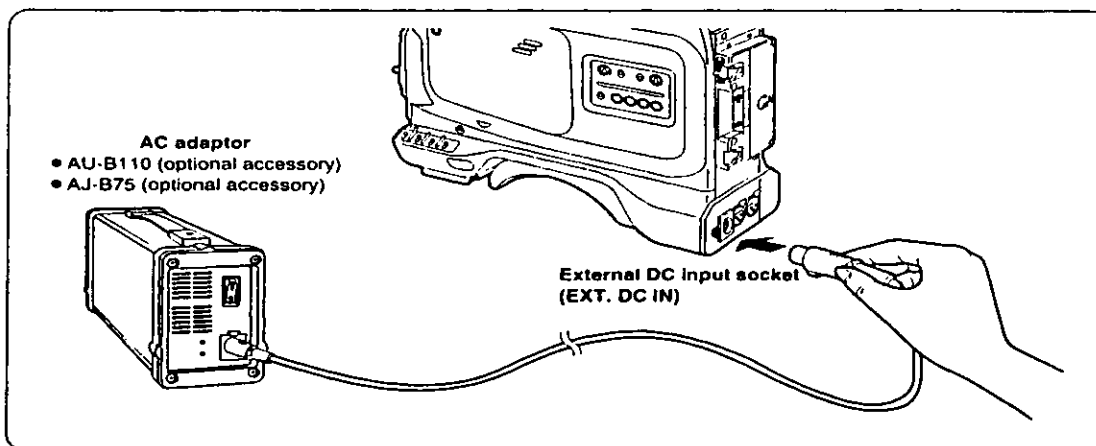

- 2** Turn on the AC adaptor's power.

- 3** Set the unit's POWER switch to the ON position.

Check the pin signals of the external DC input socket when an external power source other than the AU-B110/AJ-B75 AC adaptor is to be used.

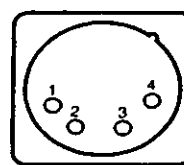
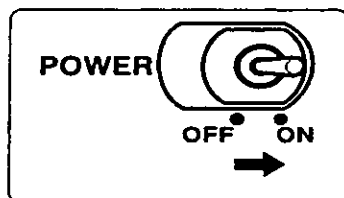

Pin No.	Signal
1	GND
2, 3	—
4	+12V

Notes:

- Priority is given to the power supplied from the AC adaptor when both a battery pack and AC adaptor have been connected.
- When the AC adaptor is used, the low battery warning may appear depending on the BATT.SELECT menu setting. If this happens, it is recommended that the Ni-Cd12V setting be used for BATT.SELECT.
- When the AC adaptor is used, the AC adaptor's power must be turned on before the unit's POWER switch is set to the ON position. If the POWER switch is set to ON first, the unit may malfunction since the AC adaptor's output voltage increases slowly after the power has been turned on.

Attaching the microphone holder (option)

The AJ-MC700/WM-L30 or other optional microphone can be used in place of the microphone which accompanies the unit.

1 Remove the microphone on the main unit.

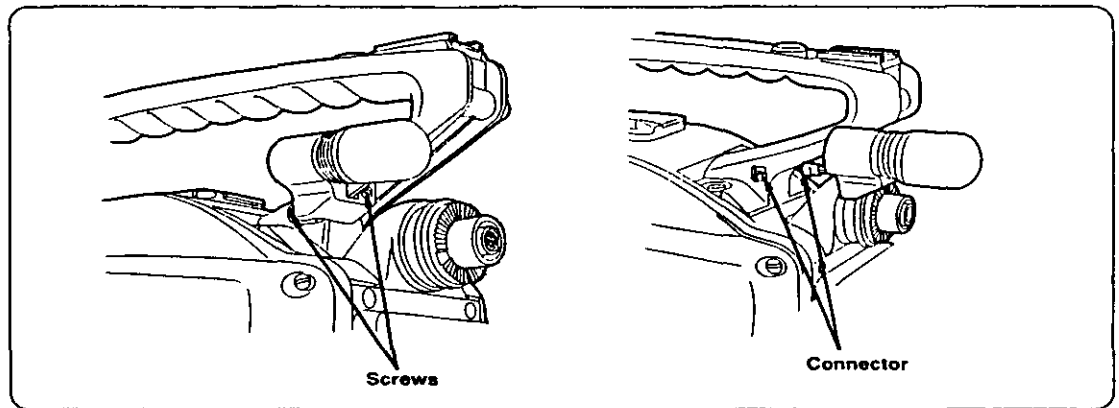

Remove the two screws to remove the connector and then remove the microphone.

2 Attach the microphone holder.

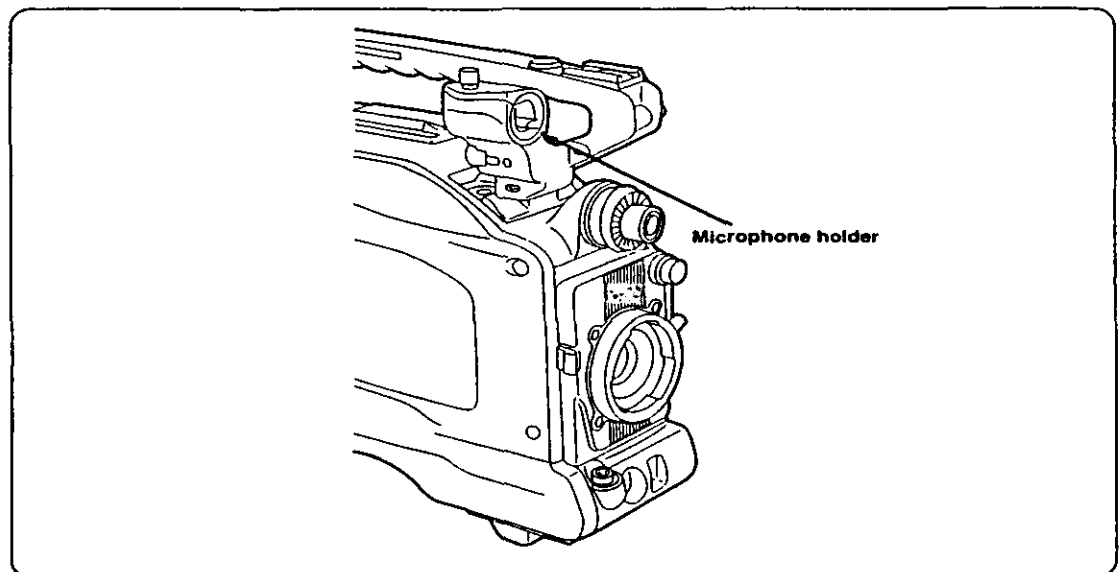

The microphone holder is attached by following the microphone removal procedure in reverse.

Mounting the unit onto a tripod

The tripod mount adaptor, which is sold separately, is used to mount the unit onto a tripod.

1 Attach the tripod mount adaptor to the tripod.

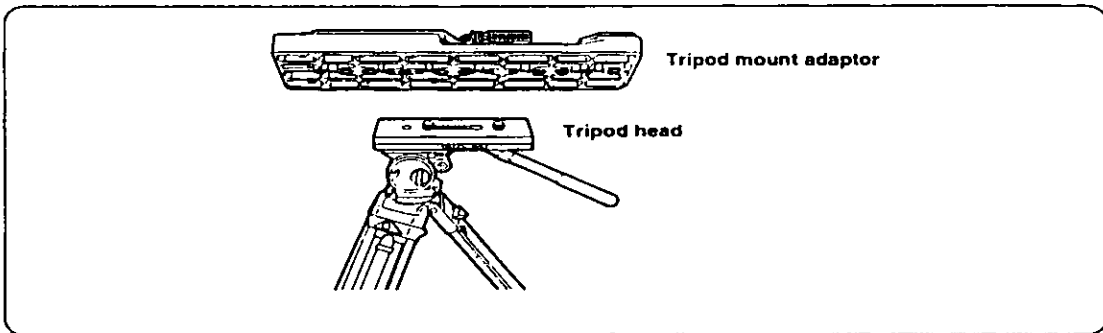

NOTE: Take the center of gravity of the unit and tripod mount adaptor into consideration when selecting the hole for the attachment. Also check that the diameter of the hole selected matches the diameter of the tripod head screw.

2 Mount the unit onto the tripod mount adaptor.

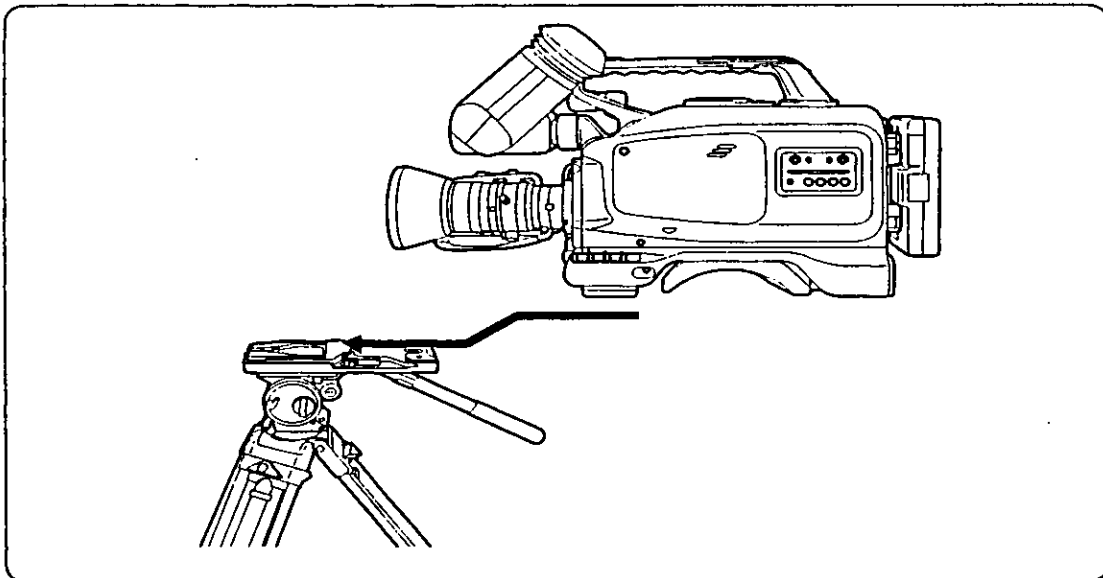

Slide the unit away from you along the groove until it clicks into position.

Disengaging the unit from the tripod mount adaptor

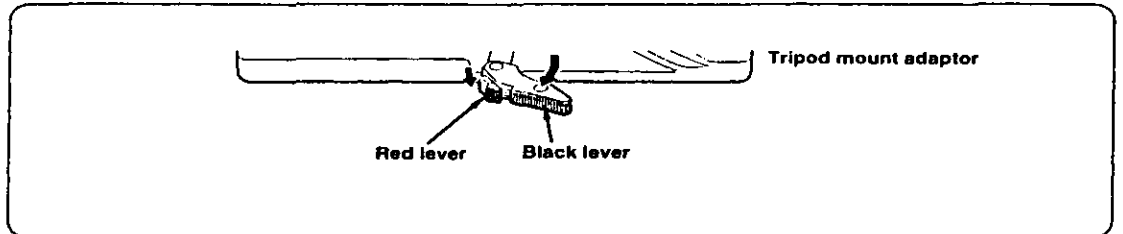

Move the black lever in the direction indicated by the arrow while holding down the red lever, and disengage the unit by sliding it toward you.

NOTE:

If the pin of the tripod mount adaptor fails to return to its original position after the unit has been disengaged, again move the black lever in the direction indicated by the arrow while holding down the red lever. This returns the pin to its former position. Bear in mind that the unit cannot be mounted if the pin is left in the center.

Fastening the shoulder belt (option)

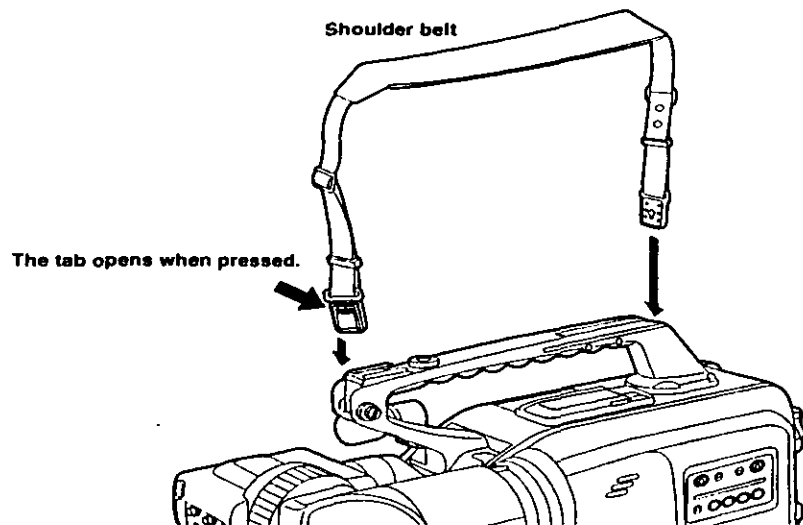

To release the shoulder belt, open the tabs at both ends and disengage.



NOTE:

Check that the shoulder belt is securely fastened.

Adjusting the shoulder pad position

The shoulder pad can be adjusted by sliding it in the forward or backward direction from its center position (shipment position) by up to 15 mm on either side. Adjust it to the position where you find it easiest to operate.

- 1** Loosen the two screws.
- 2** Slide the shoulder pad back and forth until you find the optimum position.
- 3** Tighten the screws and secure the shoulder pad.

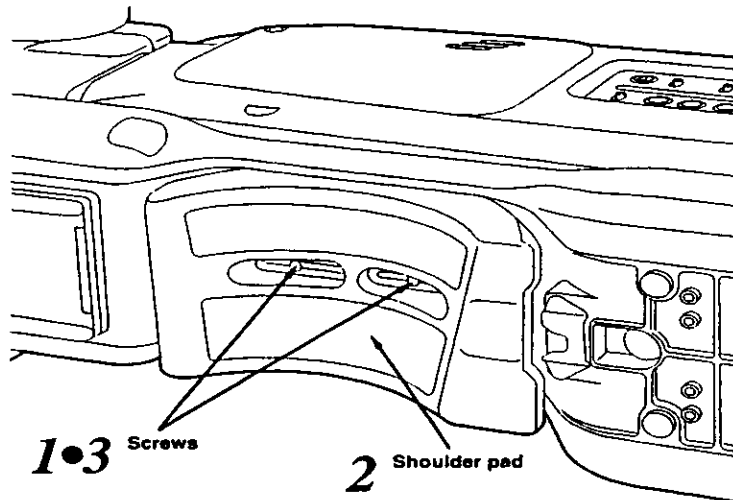

Bottom section

■ Setting the date and time

The first step to take after purchasing the unit is to set the date and time.

(With a DVCPRO VTR, the shooting date and time data is recorded separately from the images. In order for this data to be recorded correctly, first set the date and time.)

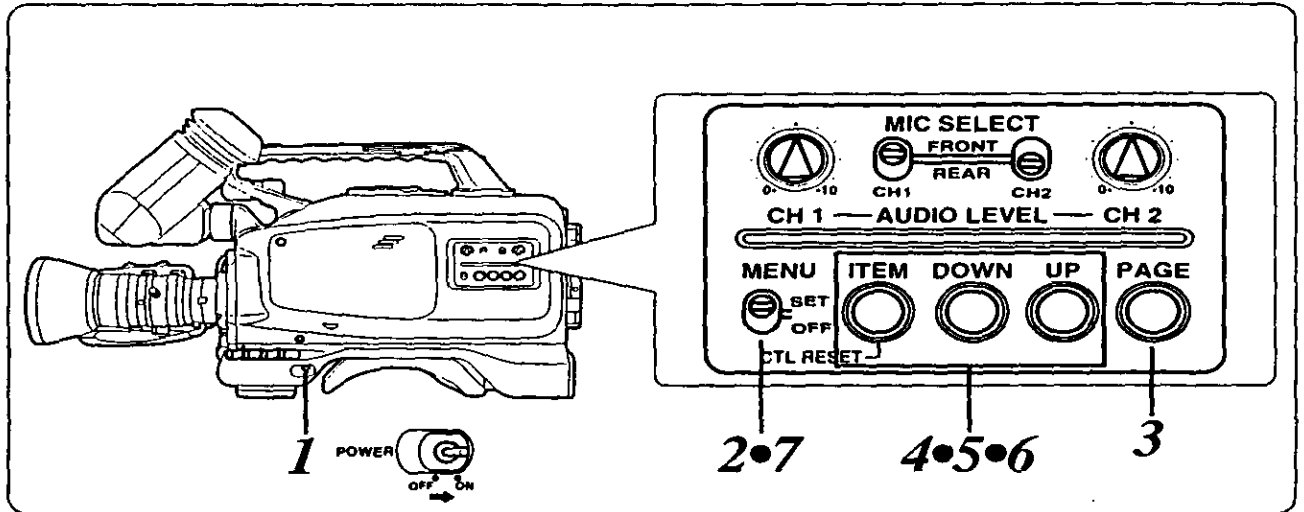

- 1** Set the POWER switch to ON.
- 2** The setting screen (MENU) appears in the viewfinder when the MENU SET/OFF selector switch is set to SET.
- 3** While monitoring the viewfinder, press the PAGE button until the TIME/DATE screen appears.

Setting screen (viewfinder)

(First setting screen for menu items)

- MAIN FUNCTION -	
→ TCG CLEAR	
RECRUN/FREERUN	: REC
DF/NDF	: DF
SCENE DATA SAVE	
SCENE DATA UNDEL	
BATT. SELECT	: DIGIT
BACK TALLY	: ON
MENU INITIALIZE	

→
Keep
pressing
the PAGE
button.

- TIME/DATE -	
→ YEAR	: 97
MONTH	: 06
DAY	: 13
HOUR	: 10
MINUTE	: 02
■ TIME/DATE SET	

Descriptions are also given in the menu items (on pages 48, 49 and 54).

4 Set the date and time using the ITEM, UP and DOWN buttons.

5 Keep pressing the ITEM button until the arrow indicates
"■ TIME/DATE SET."

Setting screen (viewfinder)

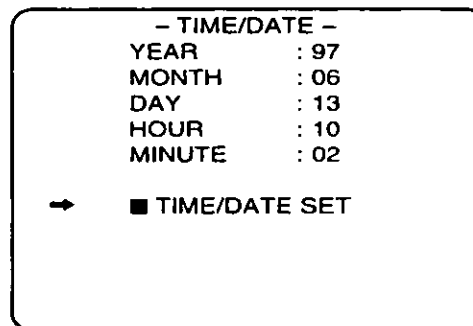

6 The date and time settings are entered when the UP or DOWN button is pressed.

7 Finally, set the MENU SET/OFF selector switch to OFF.

■ Adjusting the viewfinder

Adjusting the viewfinder diopter

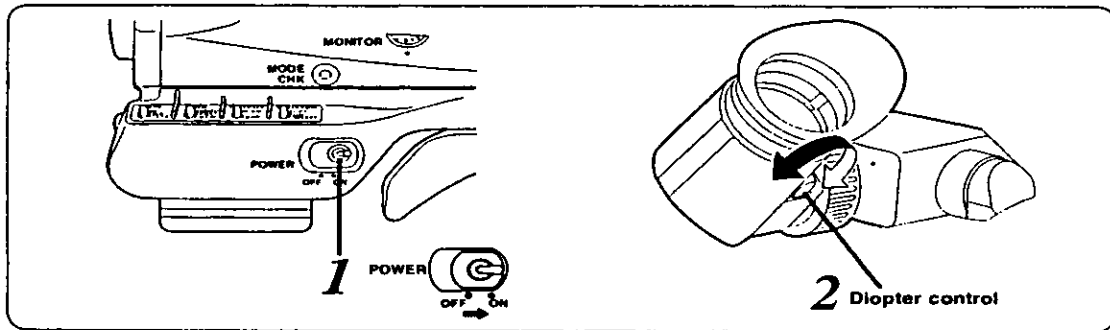

1 Set the POWER switch to ON.

An image now appears on the viewfinder.

2 Turn the diopter control and adjust it so that the viewfinder image can be seen clearly.

Adjusting the viewfinder's brightness and contrast

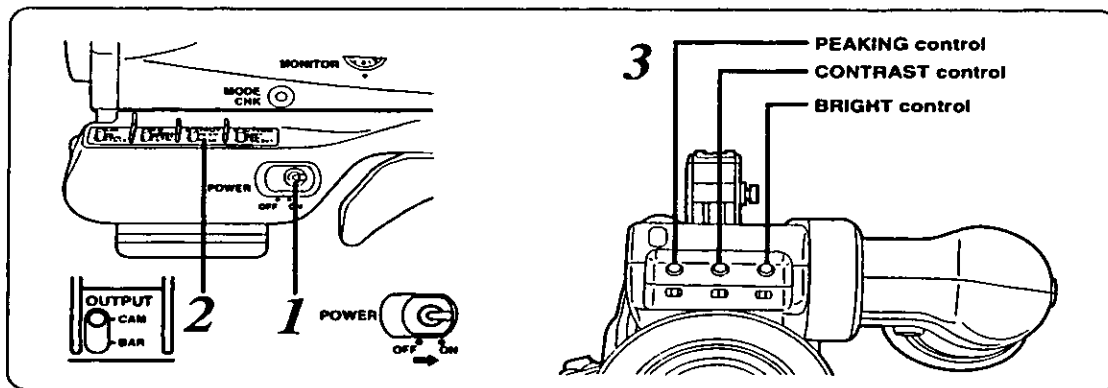

1 Set the POWER switch to ON.

An image now appears on the viewfinder.

2 Set the OUTPUT switch to CAM.

3 Turn the viewfinder's BRIGHT and CONTRAST controls and adjust the brightness and contrast of the image.

When the viewfinder's PEAKING control is turned, the image can be adjusted to be softer or sharper.

If it is adjusted to be sharp, it will be easier to focus the lens.

■ Adjusting the lens flange

The lens flange is adjusted when the lens fails to be focused at both the telephoto and wide-angle positions because it has been mounted for the first time or because it has been replaced.

This adjustment need be done only once provided that the lens is not replaced.

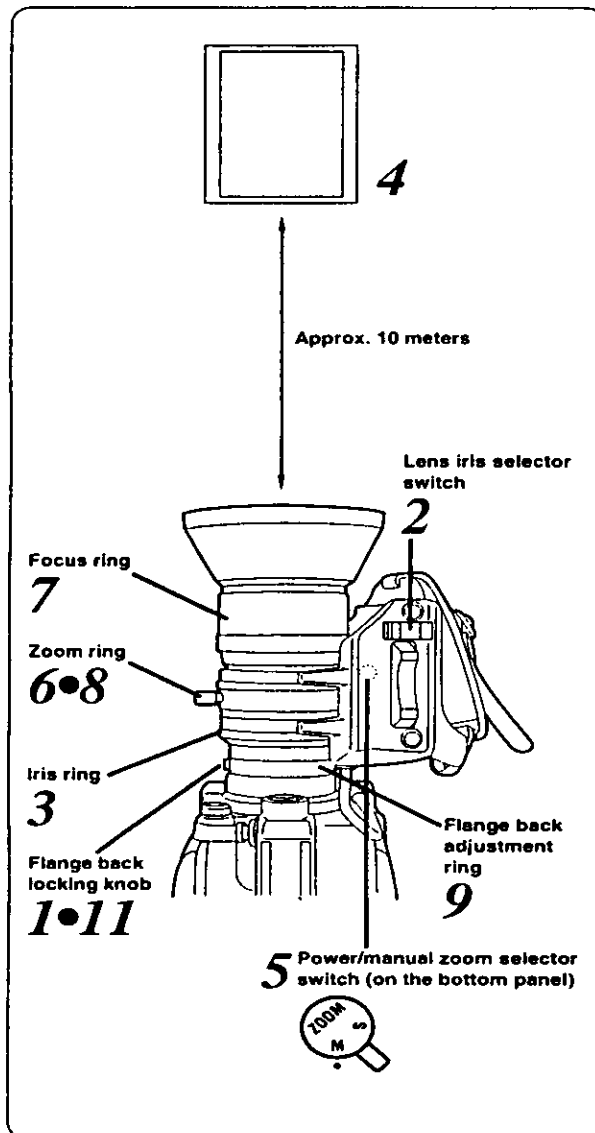

- 1** Loosen the flange back locking knob.
- 2** Set the lens iris selector switch (IRIS) to "M."
- 3** Turn the iris ring and set the iris to the fully open position.
- 4** Shoot a well-contrasted subject such as a window or utility pole at least 10 meters away.
- 5** Set the power/manual zoom selector switch to "M."
- 6** Turn the zoom ring and set the zoom to the maximum telephoto position (zoom in).
- 7** Turn the focus ring and bring the subject into focus.
When the subject is too bright and it is hard to verify whether it is in focus: Set the electronic shutter to ON. (If necessary, change the shutter speed as well.)
- 8** Turn the zoom ring and set the zoom to the maximum wide-angle position (zoom out).
- 9** Turn the flange back adjustment ring and bring the subject into focus.
- 10** Repeat steps 5 to 9 until the subject is brought into focus at both the telephoto

If the subject is out of focus, use the focus ring to focus, then zoom out, and use the flange back adjustment ring to bring the subject into focus.

- 11** Upon completion of the adjustments, tighten up the flange back locking knob to prevent the flange back adjusting ring from moving out of position.

Also refer to the operating instructions accompanying the lens you have purchased.

Adjustments during shooting

Camera posture

If the camera is held rather than secured on the tripod for shooting, the images will feature plenty of movement but there will be a lack of stability. Hold the camera in such a way as to prevent camera shake.

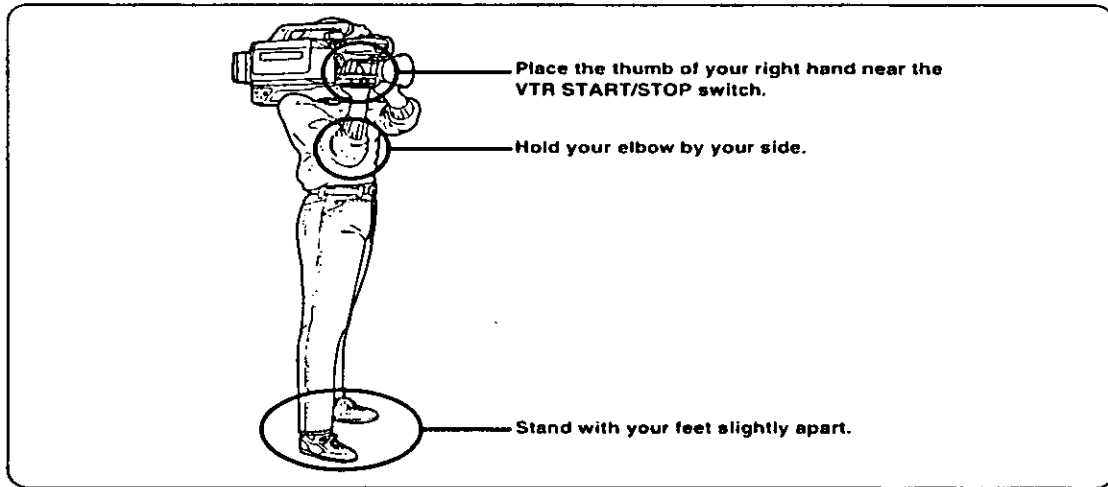

Camera movements

Basically, the camera should be fixed in position for shooting. If the pan and tilt functions are used, however, the recording will have more of a sense of movement. Moving the camera horizontally is called "panning"; moving it perpendicularly is known as "tilting." In moving the camera, the knack is to move it slowly. Better shots can be taken by moving the camera very slowly.

Even when a movement has been completed, suspend all movement for a few moments.

Panning

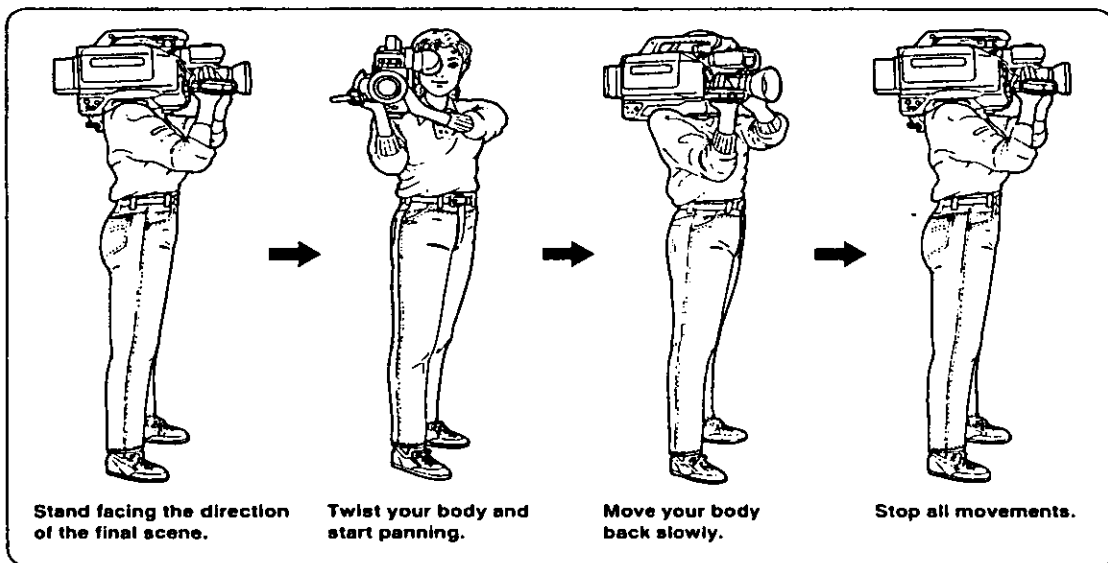

Exposure adjustment

The exposure varies according to the lens iris.

The lens iris can be adjusted using the automatic iris or manual iris settings.

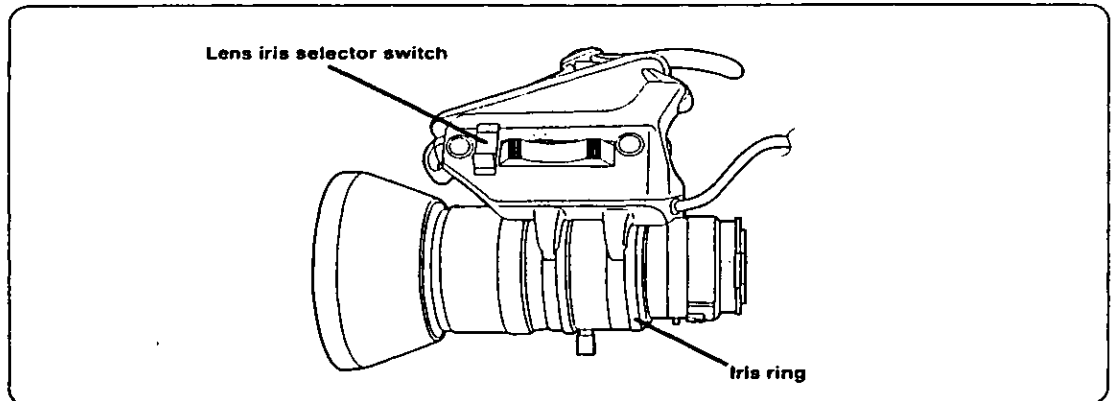

• Automatic iris

Set the lens iris selector switch (IRIS) to "A."

The iris is automatically adjusted to obtain the brightness which is commensurate with the subject.

■ This unit's automatic iris operation serves to measure the average brightness of the entire screen to control the iris. This means that the subject will tend to become all white or dark when a spotlight is directed on the subject or when the subject is shot under backlight conditions. Use the lens iris at the manual setting for lighting conditions such as these.

• Manual iris

Set the lens iris selector switch (IRIS) to "M."

Turn the iris ring and adjust the brightness.

Shooting conditions	Operation
Background is too bright, and subject is dark (backlight)	Open the iris slightly.
Background is dimly lit, and subject is bright	Stop down the iris slightly.
When special effects are desired	Adjust the iris as required.



Also refer to the operating instructions accompanying the lens you have purchased.

Note: ■ Use the built-in ND filter if there is too much light.

Zooming

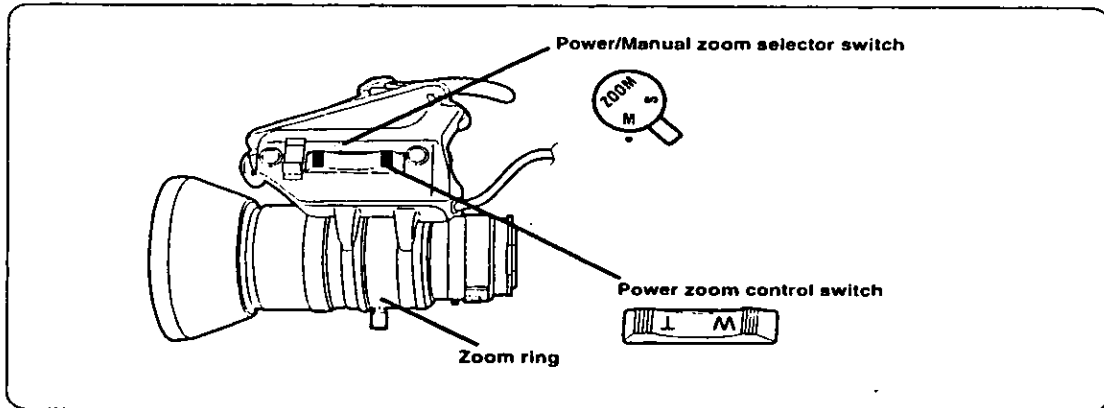
Both power zoom and manual zoom functions are available for zooming. Power zoom involves simply pressing a switch and selecting telephoto (TELE) or wide angle (WIDE); manual zoom involves operating the zoom ring and selecting telephoto or wide angle.



	Power zoom	Manual zoom
Zooming	Set the power/manual zoom selector switch to "S."	Set the power/manual zoom selector switch to "M."
Telephoto 	Set the power zoom control switch to T (TELE).	Rotate the zoom ring downward.
Wide angle 	Set the power zoom control switch to W (WIDE).	Rotate the zoom ring upward.

Also refer to the operating instructions accompanying the lens you have purchased.

How to take close-ups

The close-up (macro) function comes in handy when shooting insects, flowers or other subjects positioned at close distances of up to 1 meter or so from the unit.

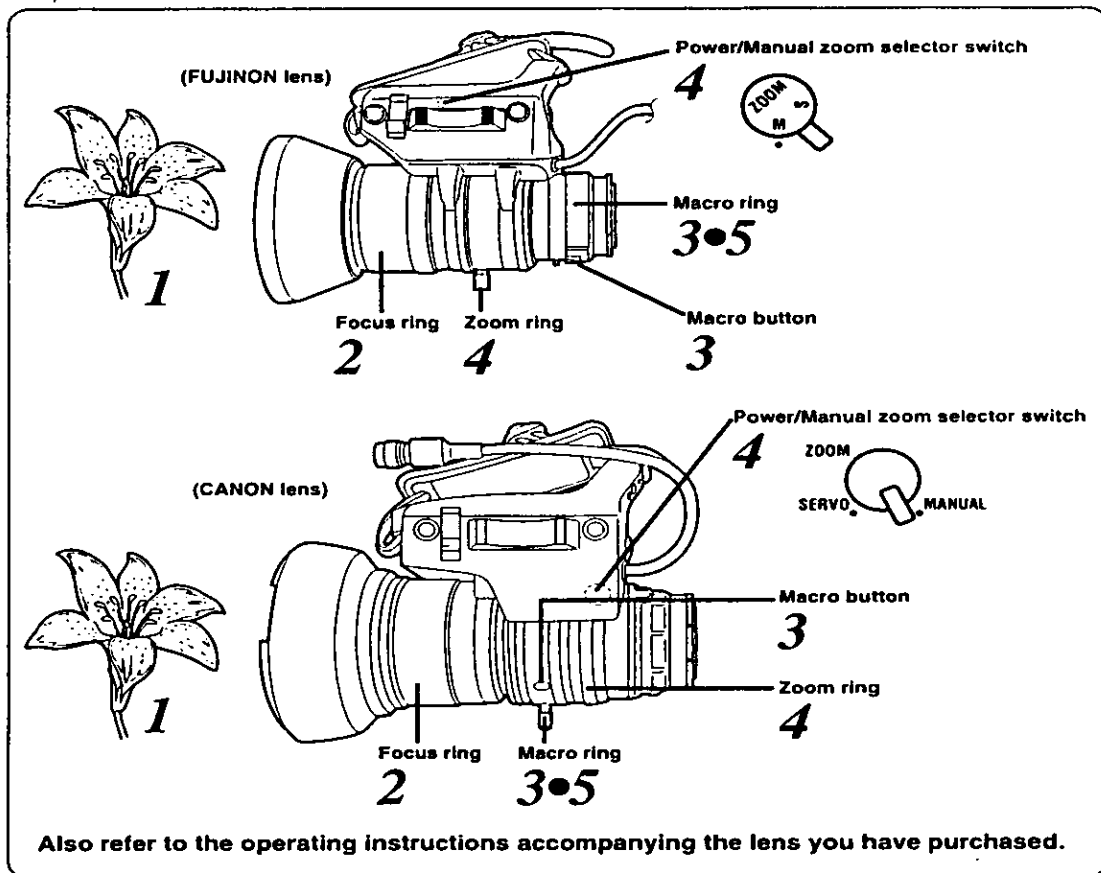

- 1** Bring the lens up close to the subject.
- 2** Set the focus ring to the shortest possible setting.
- 3** Press the **MACRO** button forward, and rotate the macro ring.
The subject appears at its maximum size when the macro ring is rotated as far as it will go.
- 4** Set the power/manual zoom selector switch to "M," and rotate the zoom ring to bring the subject into focus.
- 5** After completing the macro shooting, return the macro ring to its click-stop position.

Light sources and color temperatures

When shooting a subject, it is necessary to adjust the white balance to a setting which matches the light source. A light source is expressed using a color temperature (K). The bluer the light, the higher the temperature; conversely, the redder the light, the lower the temperature. The table given below shows the correlation between light sources and color temperatures.

Light source	Color temperature (K)	
Clear skies	10,000	
Cloudy	8,000	Blue
Rainy	7,000	
Fluorescent lights (daylight)	6,000	
Sunshine at midday	5,000	White
Mercury-vapor lamps		
Fluorescent lights (white)		
1 hour after sunrise, 1 hour before sunset	4,000	
Fluorescent lights (warm white)	3,500	
Studio lights	3,200	Yellow
Halogen lamps, video lights	3,000	
30 minutes after sunrise, 30 minutes before sunset		
Incandescent bulbs	2,500	
Sodium lamps		
(Lighting inside tunnels)		
Sunrise, sunset		
Candlelight	2,000	red

White balance adjustment

This adjustment may be skipped when the white balance selector switch is used at the ATW position (automatic tracking wide balance mode) or PRST position (for shooting under a predetermined light source).

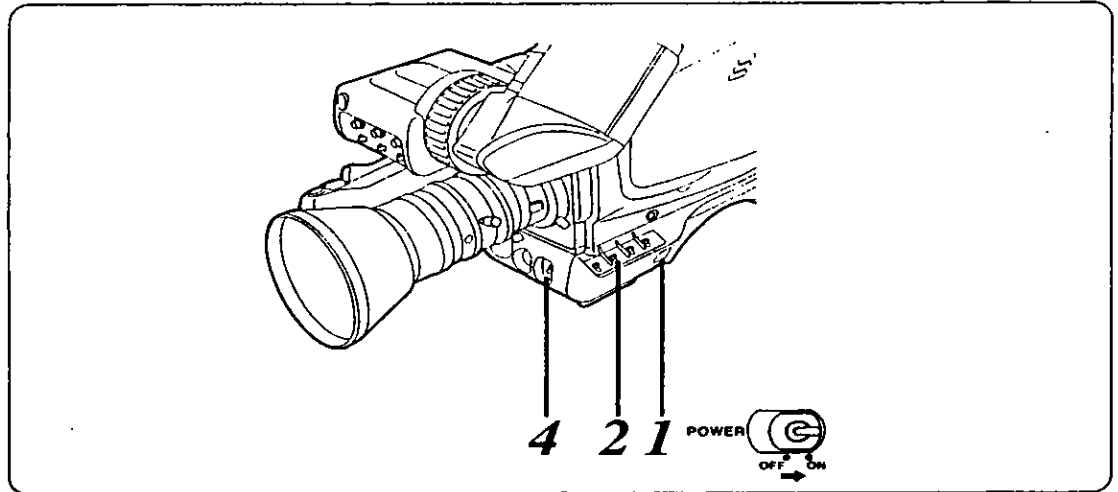

1 Set the POWER switch to ON.

2 Set the white balance selector switch to MEMO.

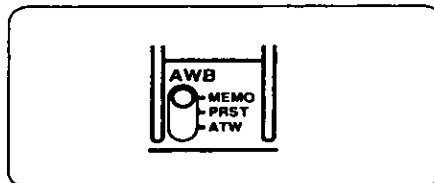

3 Place a sheet of white paper, handkerchief or something similar in conditions identical to those of the light sources which will be used to illuminate the subject, and zoom in on the subject so that the screen is filled with the white paper or handkerchief.

- Something white (such as a piece of white fabric or white wall) near the subject may serve instead, but it should be borne in mind that what you thought was white may in fact be slightly coloured.
- Be careful not to open the lens iris too far when adjusting the white balance. Attempting to adjust the white balance with the iris open too far will cause the warning "TOO BRIGHT" to be displayed and processing to stop. Note that the "TOO BRIGHT" warning is especially prone to appear when the entire screen is filled with something white, such as a piece of paper.

(Generally speaking, selecting the AUTO IRIS mode to control the lens iris setting will ensure that it is automatically adjusted to the appropriate setting for the lighting level.)

4 Shoot the white object so that it fills the screen, and set the AUTO W/B BAL switch to AWB.

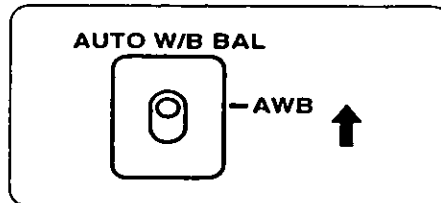

How to use the automatic tracking white (ATW) balance mode
The automatic tracking white balance mode is established when the white balance selector switch (AUTO W/B BAL) is set to the ATW position. However, since the ambient light conditions may make the auto tracking white balance operation unstable, learn how to use the MEMO, PRESET and ATW modes to best suit the prevailing conditions.

Examples

- When shooting a subject illuminated by a spotlight, proceed in the PRESET (INDOOR mode).
- If you know ahead of time that you will be shooting a subject outdoors, store the white balance setting in the MEMO position.
- Shooting a subject illuminated by a mixture of light from fluorescent lighting and incandescent bulbs or by a mixture of outdoor light and fluorescent lighting because the subject is by a window presents difficulties for automatic tracking. Under conditions such as these, adjust the white balance manually.

Use the ATW balance mode only in an emergency when you do not have the time to adjust the white balance manually.

The white balance adjustment is completed is about 10 seconds.

- Upon completion of the adjustment, the color temperature display appears in the viewfinder. Now check that the color temperature imaged and the color temperature displayed in the viewfinder match. If they do not tally, it is recommended that the white balance be adjusted again.
- If it was not possible to adjust the white balance, the WHITE BAL ERROR TRY AGAIN message appears in the viewfinder. In a case like this, check that the lens cable is connected properly and that the subject brightness is suitable, and then adjust the white balance again.

When the white balance should be re-adjusted:

Be absolutely sure to re-adjust the white balance when there has been a change in the light conditions or when the gain setting has been changed.

Notes:

- Since hunting may occur when a zoom lens with an automatic iris mechanism is used, adjust the iris gain knob provided on the lens. For further details, refer to the operating instructions accompanying the lens.
- The white balance cannot be adjusted if the white balance selector switch is set to the ATW or PRST position.
- Do not allow a subject lighter than the white object shot in step 3 above onto the screen since the white balance is adjusted with the lightest part of the subject on the screen taken to be white. Failure to heed this caution may cause malfunctioning.
- Do not increase the gain to an unnecessarily high value and then proceed with the automatic white balance (AWB) operation. Failure to heed this caution will cause the iris to be nearly stopped down when AWB is performed so operation will become unstable.

Remarks:

- In order to ensure that a high picture quality is maintained, it is recommended that AWB be performed immediately before shooting scenes of great importance or value.
- When the white balance is adjusted, the black balance is also adjusted automatically inside the unit. Consequently, when the AUTO W/B BAL switch has been operated, the iris will close before opening again: this is normal and not indicative of any malfunctioning.

Normal recording

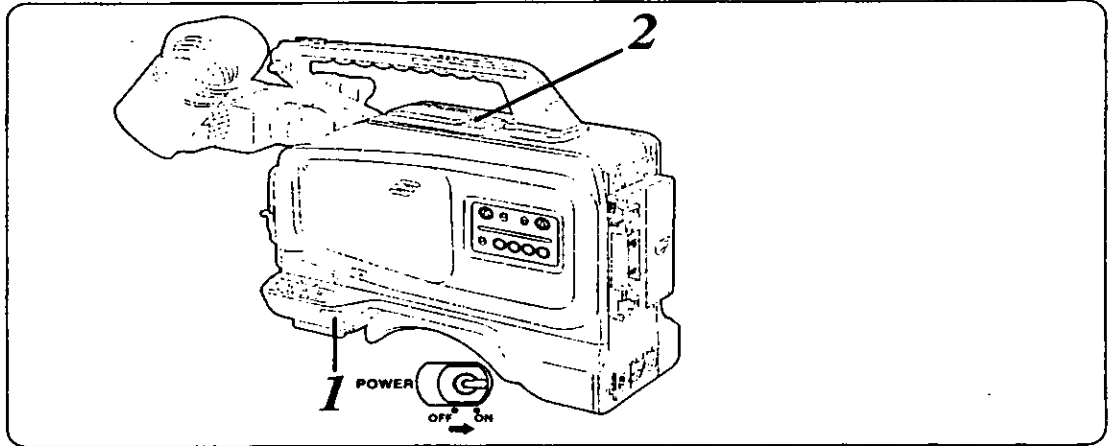

1 Set the POWER switch to ON.

2 Press the EJECT button to open the cassette holder, and insert the cassette tape.

- Before proceeding with the recording, make sure that the cassette tab has been set to the REC position.
- This unit uses "L" cassettes only.



3 Set the camera switches as shown below.

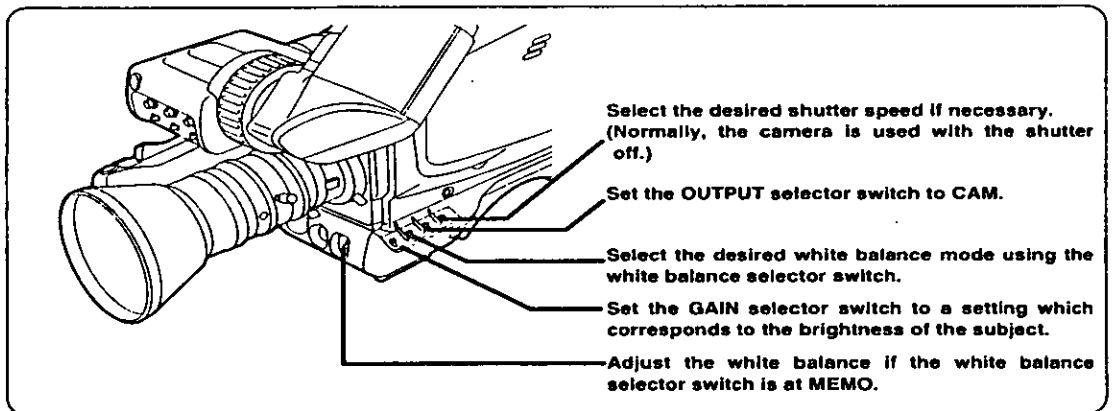

4 Point the camera at the subject and adjust the focus and zoom.

5 Press the VTR START/STOP button to start the recording.

6 Press the VTR START/STOP button to stop the recording.

Zebra pattern display

A zebra pattern can be displayed on a bright part (over approx. 85 IRE) of the image.

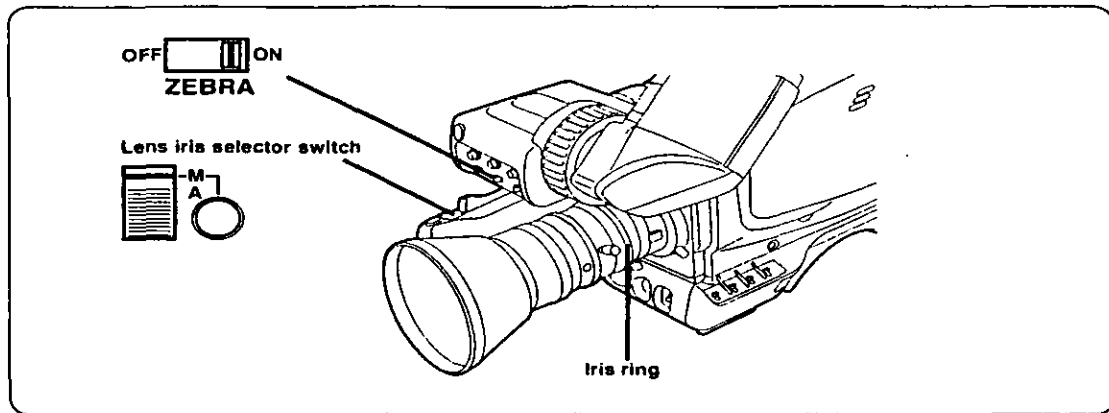

Gain settings

When shooting in locations with insufficient lighting, a brighter image can be produced by increasing the gain. However, it should be borne in mind that the noise will also increase when the gain is raised.

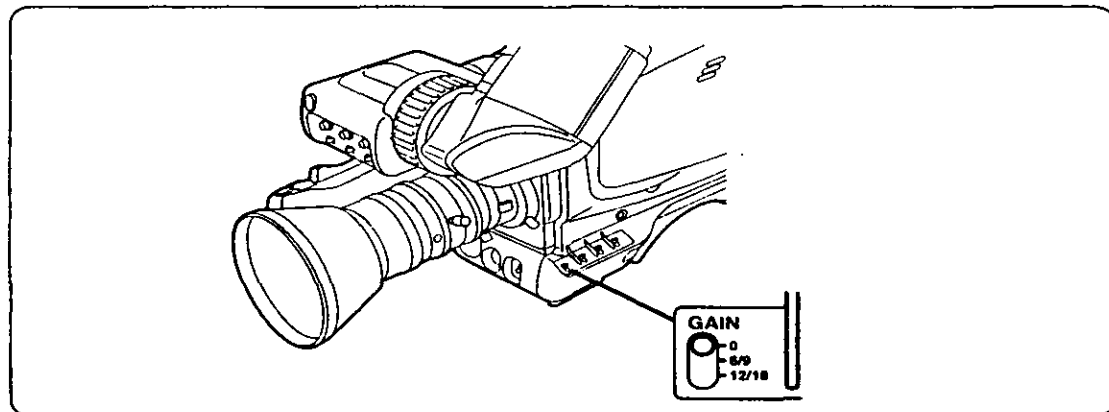

Gain settings of 0/6/12dB or 0/9/18dB are set on the menu item CAMERA SETTING menu screen for operation. (The 0/6/12dB settings were selected when the unit was shipped from the manufacturing plant.) For further details, refer to the menu items (on pages 48, 49 and 53).

High-speed shutter

Camera shake can be minimized when shooting moving subjects by increasing the shutter speed. Furthermore, shooting under fluorescent lights produces flickering images, and this flickering can be reduced by changing the shutter speed when shooting.

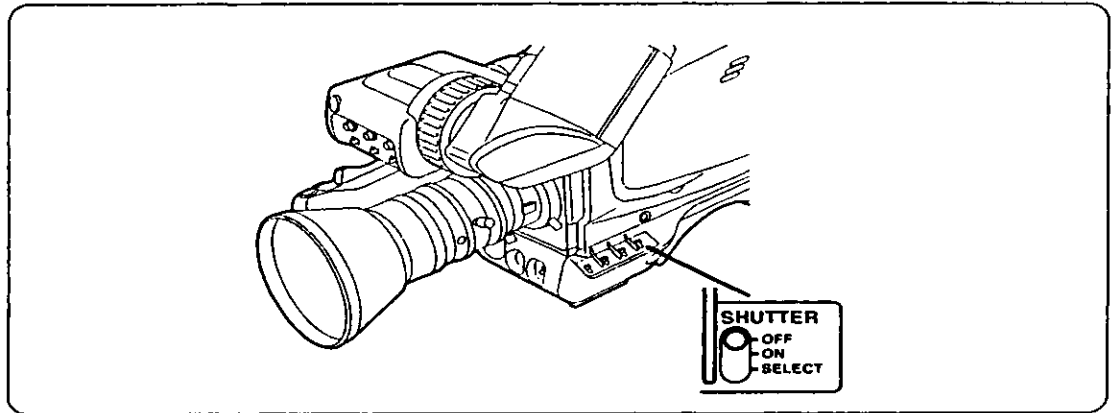

How to change the shutter speed

The SHUTTER switch is non-locking at the SELECT position. Each time it is operated at this position, the shutter speed changes in the following sequence: 1/100→1/125→1/250→1/500→1/1000→1/2000→1/4000→1/8000. When operated again at the 1/8000 setting, the speed returns to 1/100.

Notes:

- The higher the shutter speed setting, the darker the images will become. Check the brightness of the images in the viewfinder, and adjust the lighting and lens iris.
- When shooting extremely bright subjects with the shutter speed at a high setting, the smear effect (a form of distortion in which objects appear stretched out vertically) may be more noticeable than in the shutter OFF condition: this is normal and not indicative of any malfunctioning.

Audio recording

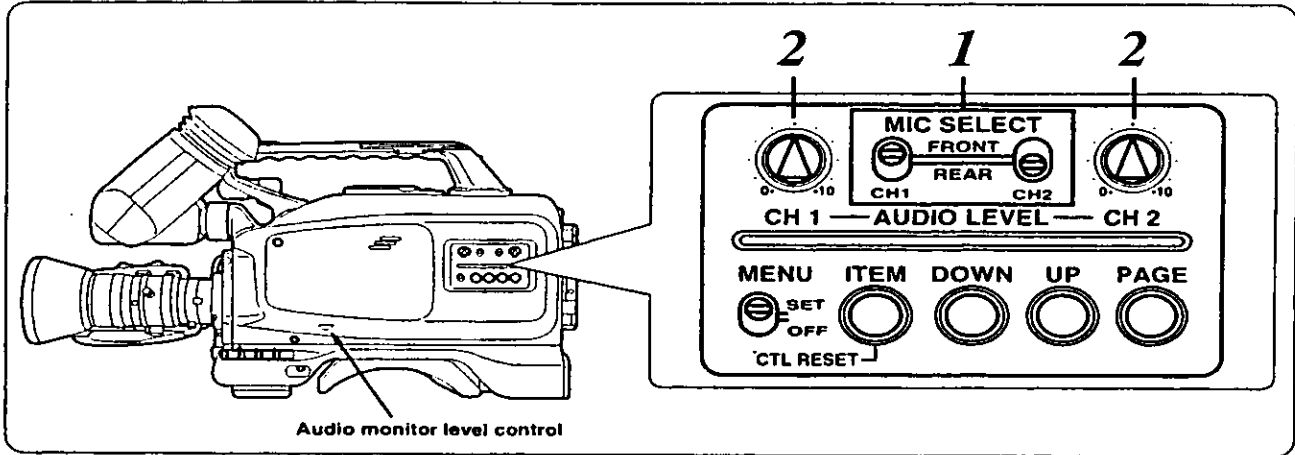

- 1** Select the desired input signals using the audio input selector switches.

When using the built-in microphone	→ FRONT
When using external microphones	→ REAR

- 2** Adjust the recording levels using the audio level controls.

The recording levels can be checked in the viewfinder. Adjust the levels in such a way that the audio level meter for the viewfinder display shows "-----+" or thereabouts.

(See page 15)

Notes: ■ Howling may occur when the volume of the sound delivered through the audio monitor speaker is too high. If this occurs, turn the audio monitor level control down to a level at which howling does not occur.

Remarks: ■ The line input can be selected instead of the external microphones by setting an internal switch to the corresponding position. For further details, refer to page 59.

Rec review

When the camera's RET button is pressed while the VTR is in the REC PAUSE mode (which is established after the tape has finished moving back automatically), rec review is conducted so that the quality of what has already been recorded can be checked.

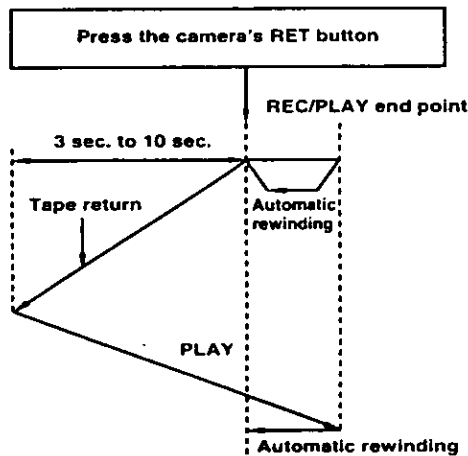

- The amount by which the tape moves backward can be controlled from 3 to 10 seconds by either pressing the camera's RET button and releasing it immediately or holding it down.
- The playback images appear in the viewfinder while the tape is being played back in the rec review mode.

<When no recording has yet been made near the rec review start point>
The playback images of the blank part of the tape appear in the viewfinder.

- Notes:**
- During the rec review operation, the rec review images are output to the video output connectors (BNC and S-VIDEO connectors) as well as to the viewfinder. It should be borne in mind that these rec review images will be recorded if a back-up VTR has been connected to record back-up images.

Retake

When the FF or REW button is pressed in the REC PAUSE mode, playback images at 1× normal tape speed or reverse playback images at 1× normal tape speed can be viewed while the button is held down. When the button is released, the REC PAUSE mode is re-established immediately. This function can be used to retake shots by running the tape to the desired position while checking the images and by starting recording again from that position.

Still-picture playback

The STILL mode is established when the PLAY button is pressed during playback. Both the FF and REW LED displays in the operation section light up at this time. Normal playback is resumed when the PLAY button is pressed again.

Menu items

Setting procedure

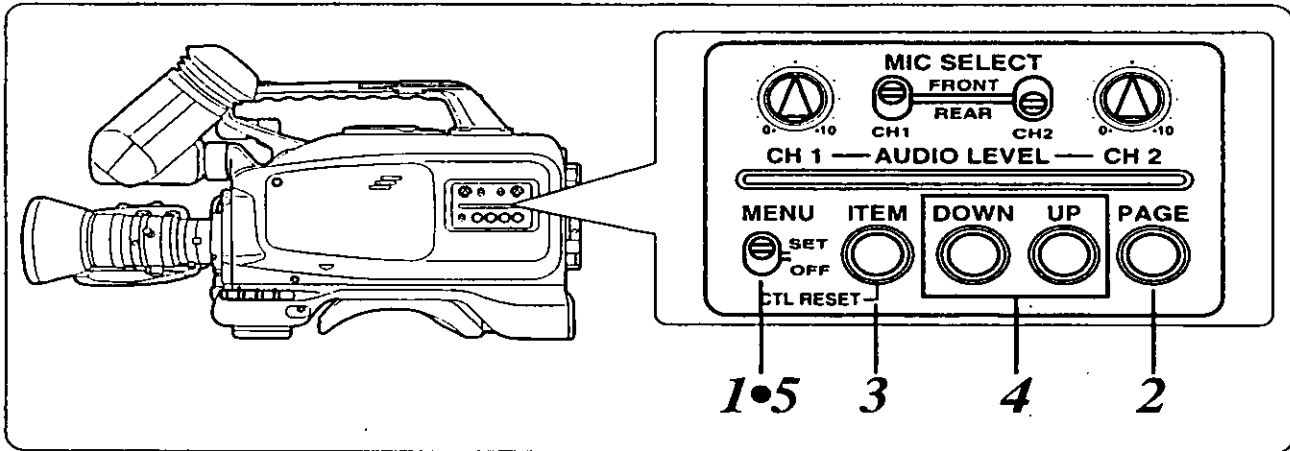

1 Set the MENU SET/OFF switch to SET.

When the MENU SET/OFF switch is set to SET while the unit is in the stop, eject or rec pause mode, the menu screen is displayed.

2 Press the PAGE button.

The menu screens are switched in succession as shown below by pressing the PAGE button.

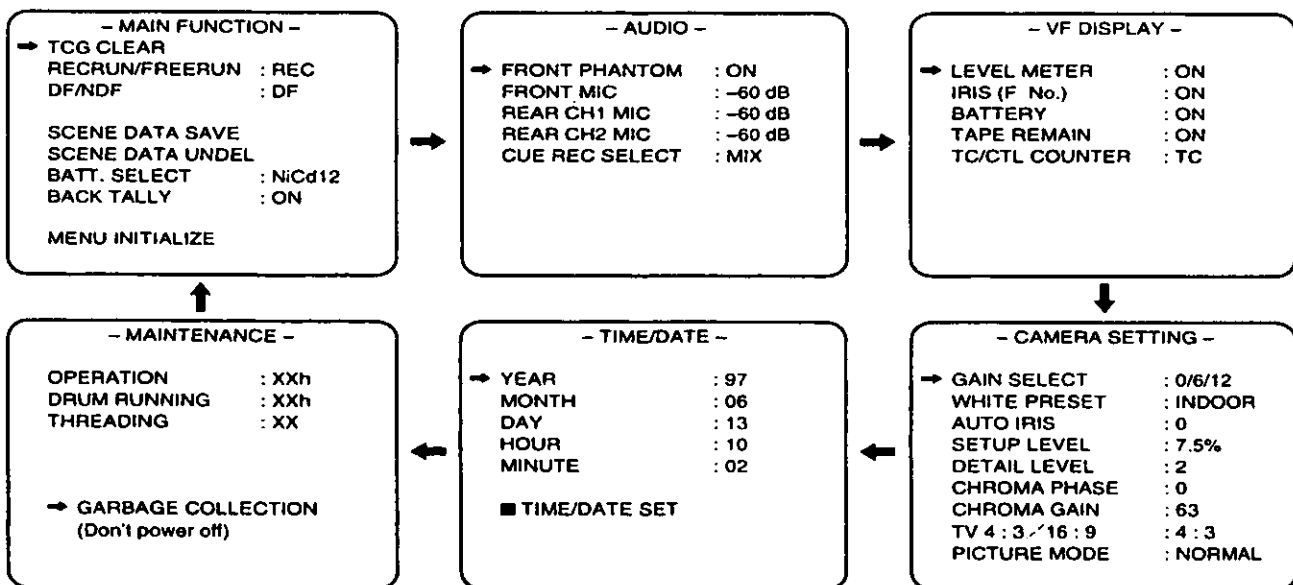

3 Press the ITEM button.

The ITEM button is pressed to select items on each of the menu screens. Each time the ITEM button is pressed, the arrow at the left of the screen moves. The item indicated by the arrow is the item currently selected.

4 Press the UP or DOWN button.

Press the UP or DOWN button to change the setting.

5 Upon completion of the settings, set the MENU SET/OFF switch to OFF.

The original viewfinder screen is restored.

Notes: The setting data is stored in the built-in flash memory several seconds after the MENU SET/OFF switch has been set to the OFF position. Bear in mind that the data will not be stored correctly if the battery or AC adaptor is removed while the MENU SET/OFF switch is still at SET or immediately after the switch was changed to the OFF setting.

MAIN FUNCTION menu

- MAIN FUNCTION -	
→ TCG CLEAR	
RECRUN/FREERUN	: REC
DF/NDF	: DF
SCENE DATA SAVE	
SCENE DATA UNDEL	
BATT. SELECT	: DIGIT
BACK TALLY	: ON
MENU INITIALIZE	

Menu item	Mode setting	Description of function
TCG CLEAR		Clears the time code generator.
RECRUN/FREERUN	<u>REC</u> FREE	Selects whether the time code generator is to be used in the REC RUN or FREE RUN mode. Regeneration is conducted if REC RUN mode is selected.
DF/NDF	<u>DF</u> NDF	Selects whether the time code generator is to be operated in the drop frame or non-drop frame mode.
SCENE DATA SAVE		Stores the SCENE data on the tape. (Refer to the section on SCENE data on pages 56 and 57.)
SCENE DATA UNDEL		Restores the SCENE data. (Refer to the section on SCENE data on pages 56 and 57.)
BATT. SELECT	<u>NiCd12</u> NiCd13 NiCd14 DIGIT	Selects the type of battery to be used. NiCd12: For an AC adaptor or a 12 V nickel-cadmium battery. NiCd13: For a 13.2 V nickel-cadmium battery. NiCd14: For a 14.4 V nickel-cadmium battery. DIGIT: For a digital nickel-cadmium battery (same for both 13.2 V and 14.4 V).
BACK TALLY	<u>ON</u> OFF	ON is selected if the back tally LED display is to be used; OFF is selected if it is not to be used.
MENU INITIALIZE		Restores all the menu items to the settings established before the unit was shipped from the factory.

The underlining for the mode settings indicates the modes selected before the unit was shipped from the factory.

AUDIO menu

- AUDIO -	
→ FRONT PHANTOM	: ON
FRONT MIC	: -60 dB
REAR CH1 MIC	: -60 dB
REAR CH2 MIC	: -60 dB
CUE REC SELECT	: MIX

Menu item	Mode setting	Description of function
FRONT PHANTOM	<u>ON</u> OFF	Sets the phantom power for the front microphone to ON or OFF. ON is selected if the microphone provided with the unit is to be used.
FRONT MIC	<u>-60 dB</u> -50 dB -40 dB	Selects the front microphone input level setting. Select -60 dB, -50 dB or -40 dB depending on the microphone used.
REAR CH1 MIC	<u>-60 dB</u> -50 dB -40 dB	Selects the rear microphone CH1 input level setting. Select -60 dB, -50 dB or -40 dB depending on the microphone used.
REAR CH2 MIC	<u>-60 dB</u> -50 dB -40 dB	Selects the rear microphone CH2 input level setting. Select -60 dB, -50 dB or -40 dB depending on the microphone used.
CUE REC SELECT	CH1 CH2 <u>MIX</u>	Selects the signals to be recorded on the CUE audio track from among the CH1, CH2 and MIX signals.

The underlining for the mode settings indicates the modes selected before the unit was shipped from the factory.

VF DISPLAY menu

- VF DISPLAY -		
→ LEVEL METER	:	ON
IRIS (F No.)	:	ON
BATTERY	:	ON
TAPE REMAIN	:	ON
TC/CTL COUNTER	:	TC

Menu item	Mode setting	Description of function
LEVEL METER	<u>ON</u> OFF	Selects whether the audio level meter reading is to be displayed on the viewfinder.
IRIS (F No.)	<u>ON</u> OFF	Selects whether the lens iris f-value is to be displayed on the viewfinder.
BATTERY	<u>ON</u> OFF	Selects whether the remaining battery charge is to be displayed on the viewfinder.
TAPE REMAIN	<u>ON</u> OFF	Selects whether the remaining tape amount is to be displayed on the viewfinder.
TC/CTL COUNTER	<u>TC</u> UB CTL OFF	Selects whether the viewfinder counter display is to show the time code, user bit, CTL or none of these.

The underlining for the mode settings indicates the modes selected before the unit was shipped from the factory.

CAMERA SETTING menu

- CAMERA SETTING -	
← GAIN SELECT	: 0/6/12
WHITE PRESET	: INDOOR
AUTO IRIS	: 0
SETUP LEVEL	: 7.5%
DETAIL LEVEL	: 2
CHROMA PHASE	: 0
CHROMA GAIN	: 63
TV 4 : 3 / 16 : 9	: 4 : 3
PICTURE MODE	: NORMAL

Menu Item	Mode setting	Description of function
GAIN SELECT	<u>0/6/12</u> 0/9/18	Selects whether the 0/6/12 dB or 0/9/18 dB settings are to apply to the operation of the camera gain selector switch.
WHITE PRESET	<u>INDOOR</u> OUTDOOR FLUOR	Selects whether OUTDOOR, INDOOR or FLUOR (fluorescent lighting) is to be set when the camera's WHITE BAL selector switch is at the PRST position.
AUTO IRIS	-3.0 : <u>0</u> : 3.0	Selects the target brightness of the auto iris. The brightness can be set in 0.1 increments from -3.0 to 3.0. Example: When -1.5 is selected, the iris is closed by approximately 1.5 stops from the factory setting. However, there may be a slight deviation from this value.
SETUP LEVEL	0% <u>7.5%</u>	Sets the camera setup level. Either 0% or 7.5% is selected.
DETAIL LEVEL	0 : <u>2</u> : 16	Finely adjusts the camera detail level. Adjustment is possible from 0 to 16.
CHROMA PHASE	-32 : <u>0</u> : 32	Finely adjusts the camera's chroma phase. Set the value in the + direction if the skin color is to be made redder or in the - direction if it is to be made more yellow. Any value from -32 to 32 can be set.
CHROMA GAIN	0 : <u>63</u>	Adjusts the camera's color intensity. The higher the value, the greater the intensity of the colors. Any value from 0 to 63 can be set.
TV 4 : 3 / 16 : 9	<u>4 : 3</u> 16 : 9	Selects whether the camera is to be used for screen dimensions of 4:3 or 16:9.
PICTURE MODE	<u>NORMAL</u> FRAME	NORMAL is selected for ordinary shooting. At the FRAME setting, pictures have the "skipped frame" effect.

The underlining for the mode settings indicates the modes selected before the unit was shipped from the factory.

TIME/DATE menu

- TIME/DATE -

→ YEAR : 97

MONTH : 06

DAY : 13

HOUR : 10

MINUTE : 02

■ TIME/DATE SET

Note: Make absolutely sure that the arrow is moved to the "■ TIME/DATE SET" position upon completion of the setting, and then press the UP or DOWN button. The settings will not be recorded unless the UP or DOWN button is pressed at the "■ TIME/DATE SET" position.

Menu item	Mode setting	Description of function
YEAR	00 : 99	Sets the last two digits of the year. Examples: "97" is set for 1997, and "01" for 2001.
MONTH	01 : 12	Sets the month using two digits.
DAY	01 : 31	Sets the day using two digits.
HOUR	00 : 24	Sets the hour (24-hour mode) using two digits.
MINUTE	00 : 59	Sets the minute using two digits.

MAINTENANCE menu

```

      - MAINTENANCE -
OPERATION      : XXh
DRUM RUNNING   : XXh
THREADING      : XX

➔ GARBAGE COLLECTION
  (Don't power off)
  
```

Menu item	Description of function
OPERATION	Indicates the number of hours during which power has been supplied to the unit to date.
DRUM RUNNING	Indicates the total accumulated number of hours during which the head cylinder has been operating to date.
THREADING	Indicates the number of times a tape was loaded to date.
GARBAGE COLLECTION	<p>Gives the command to collect the garbage in the built-in flash memory. If the "FLASH MEMORY EMPTY" message appears in the viewfinder when the power is turned on, align the arrow with "GARBAGE COLLECTION," and press the UP or DOWN button. Collection of garbage in the flash memory then commences.</p> <p>Notes:</p> <ul style="list-style-type: none"> ● Once the collection of garbage in the flash memory has commenced, no operation is possible for about one minute. Upon completion of this processing, normal operation can be resumed. ● While the garbage in the flash memory is being collected, do NOT turn off the power. Also ensure that the battery has an adequate charge during this operation. If the power is cut off during the processing, the collection of the garbage in the flash memory will be discontinued and not completed properly, and this will affect subsequent operation.

SCENE data (news gathering data recording)

If SCENE data is used for future non-linear editing or other such applications, it will be possible to do the job extremely efficiently. SCENE data is an information exchange system for enhancing efficiency during editing. It operates by gathering information for editing during shooting and recording it onto the tape.

The SCENE data information consists of the following data for each cut.

Cut 1	Recording start time code	Recording stop time code	MARK
Cut 2	Recording start time code	Recording stop time code	MARK
⋮			
Cut 200	Recording start time code	Recording stop time code	MARK

- The recording start time code and recording stop time code are automatically written.
- MARK is written by operating buttons.
- A return is made to cut 1 when the cassette tape is replaced.
- In order to ensure frame-to-frame continuity in operation, this unit returns the tape by several frames from the position of the previous cut's recording stop, and then it starts to record the next cut (this is known as overlap recording). For this reason, the position of the SCENE data information's recording stop time code is shifted slightly from the end point of the cut recorded on the tape.

I MARK operation

The "No MARK" status is established when recording starts.

MARK is an extremely simple memo (3 types: "No MARK," "MARK 1" or "MARK 2") which is inserted during shooting to facilitate editing afterwards.

Make up your own rules governing the use of these marks by, for instance, assigning "MARK 1" to one shooting session and "MARK 2" to another. When a situation arises which meets the conditions of the rules you have made up, press the MARK/CANCEL button. "MARK 1" now appears in the right corner of the viewfinder. When the MARK/CANCEL button is pressed again, "MARK 2" appears, and when the MARK/CANCEL button is pressed yet again, the CANCEL mode is established, and the "MARK" display in the right corner of the viewfinder is cleared.

When the recording of the next cut is started, this "MARK" is recorded into the internal memory, and the MARK/CANCEL button may be pressed any number of times until the next recording is started.

2 Saving the SCENE data onto the tape

The SCENE data is saved before the tape is ejected. Normally, it is saved after the final cut has been shot.

Set the menu SET/OFF selector switch to SET and display the MAIN FUNCTION MENU.

Menu item screen (viewfinder)

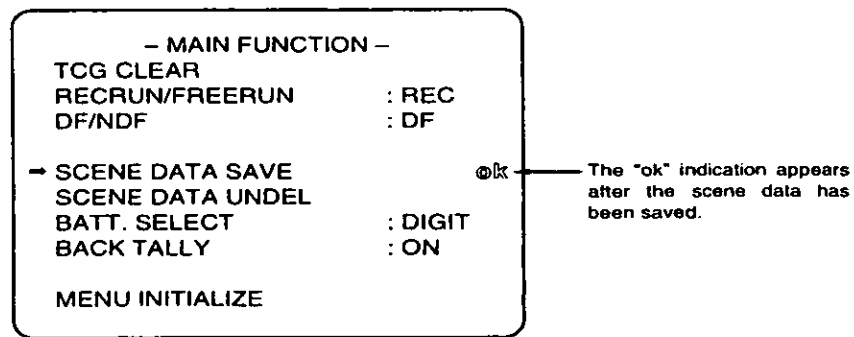

Use the ITEM button to align the arrow with the SCENE DATA SAVE position, and press the UP or DOWN button.

The color of the screen changes to green, and the VTR starts operating in the recording mode. It takes about 10 seconds for the SCENE data to be saved, after which the original viewfinder screen is restored and "ok" indication will appear.

- Notes:**
- Other operations cannot be performed while the SCENE data is being saved.
 - When the tape is ejected, the SCENE data stored to date is cleared, and the preparations are made to gather the SCENE data for the next tape.
 - SCENE data cannot be saved from the SAVE mode (which is automatically established to protect the tape when the unit has been left standing in the REC PAUSE mode for more than 30 minutes). In this case, first press the STOP button to release the SAVE mode, and then save the SCENE data.

- Remarks:**
- If it is absolutely essential for the data to be restored because you forgot to save it before the tape was ejected, reload the ejected tape, display the MAIN FUNCTION menu screen, and use the ITEM button to align the arrow with SCENE DATA UNDEL. The data can now be restored by pressing the UP or DOWN button. If the tape is reloaded after its ejection and recording is then started, the data will be rewritten by the SCENE data for the new tape. This means that the data cannot be restored.

Replacing the back-up battery

The unit is shipped from the factory with a back-up battery already installed. The "BACKUP BATTERY EMPTY" message appears in the viewfinder when the back-up battery has run down. Consult with your dealer, and replace the battery with a new one (CR2032 or BR2032).

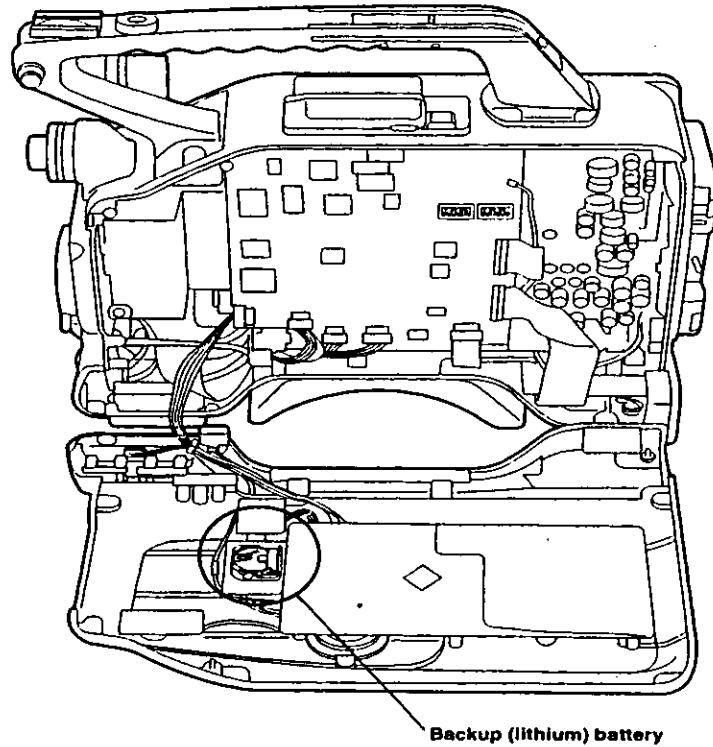

Selecting the audio input

To connect phantom microphones or the line input to the audio input connectors on the rear panel, set the internal switches (audio input selector switches) to the appropriate positions.

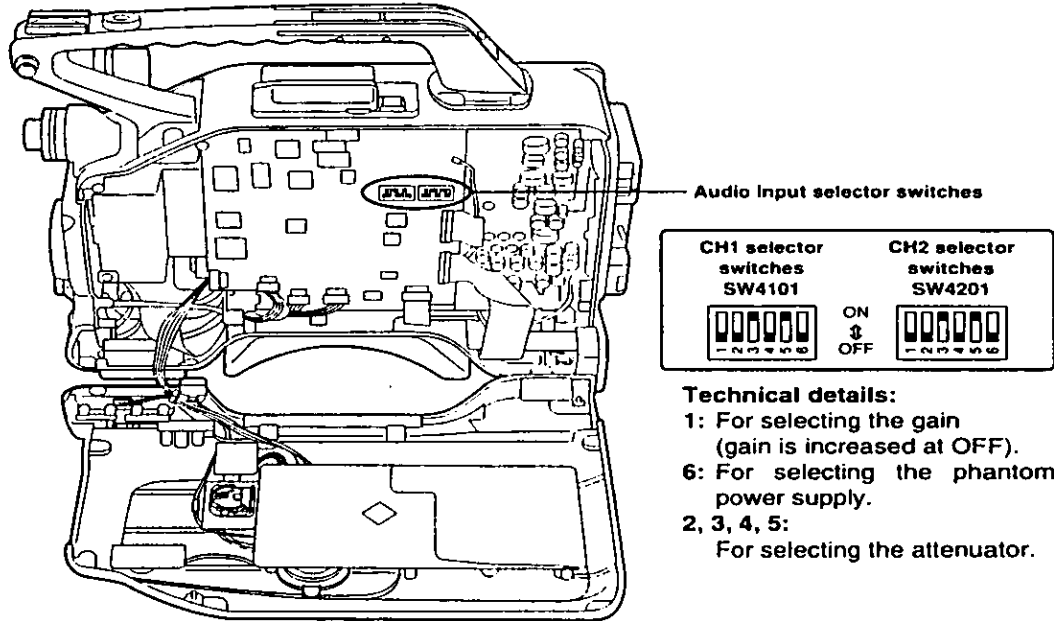

When an ordinary microphone is used (factory settings):

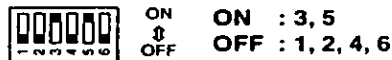

When a phantom microphone is to be used:



Set the switches to the above positions.

When the line input is to be used:



Set the switches to the above positions.

The line input level can be switched to one of three settings: -6 dB, 0dB or +4 dB.

It is set using the REAR CH1 MIC/REAR CH2 MIC menu item (on the AUDIO menu/see page 51) but the menu screen display will remain unchanged even when the internal switches are set to the positions shown above. Use the table given below as a reference to convert the input level.

Menu display	For microphone	For line input
-60 dB	-60 dB	-6 dB
-50 dB	-50 dB	0 dB
-40 dB	-40 dB	+4 dB

Tips on lighting

Studio lighting

Use halogen lamps with a color temperature of 3,000K to 3,200K for lighting in a studio. If the color temperature of the light source differs from this value, the colors of the subject will appear differently to what is seen by eye. The shadows may take on colors or the image may not appear with the proper colors.

Use lighting of 300 lux or above. If it is less than this value, the screen may appear dark, the contrast may be insufficient, the depth of focus may be shallow or the picture quality may suffer deterioration in some other way.

Ensure that the lighting is directed evenly over the entire subject and that no shadows are formed.

Consult the table below and use the figures given, which are approximations only, as a guideline for evaluating the brightness.

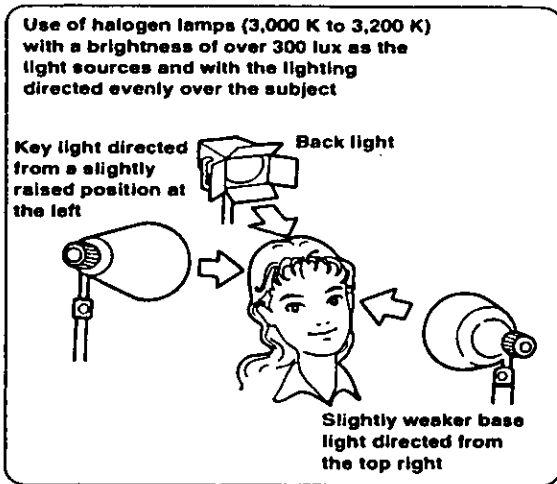

Lighting required	Lighting desired	Actual shooting without lighting	ND filter required
10	<ul style="list-style-type: none"> Brightness of a candle at 20 cm (10 to 15) Brightness of a cigarette lighter at 30 cm (15) 		
30			
50	<ul style="list-style-type: none"> Brightness underneath a street lamp (50 to 100) 		
100	<ul style="list-style-type: none"> Shopping arcade at night (150 to 200) Direct beam from a flashlight at 1 m (250) 		
500	<ul style="list-style-type: none"> Indoor area lit with fluorescent lighting (400 to 500) 		
1,000	<ul style="list-style-type: none"> Sales counters of a department store (500 to 700) Sunlight 1 hour before dusk on a clear day (1,000) 		
10,000	<ul style="list-style-type: none"> Sunlight 1 hour after dawn on a cloudy day (2,000) By a train window in the afternoon (3,500) Sunlight at 10 AM on a cloudy day (25,000) Sunlight at noon on a cloudy day (32,000) Sunlight at 3 PM on a clear day (35,000) Sunlight at 10 AM on a clear day (65,000) 		
100,000	<ul style="list-style-type: none"> Sunlight on a clear day (100,000) Outdoors at noon under a cloudless sky On the beach at the height of summer In the mountains covered with snow 		

(Unit: lux)

Notes:

- Do not expose the lens directly to sunlight or shoot a subject for a long time which is reflecting either a bright light or the light which is used for lighting.
- Flickering may result if the camera is used to shoot under fluorescent lights. Add extra lighting such as video lights (optional accessories) in cases like this.
- Use the built-in ND filter if there is too much light.

Tips on outdoor shooting

If the subject is too bright when, for instance, shooting outdoors under a clear sky, adjust the brightness either using the electronic shutter or the built-in ND filter.

Phenomena inherent to CCD cameras

The following phenomena are known to arise in CCD cameras.

Smear

Although this unit has extremely low smear characteristics, smear may arise when shooting an extremely bright subject.

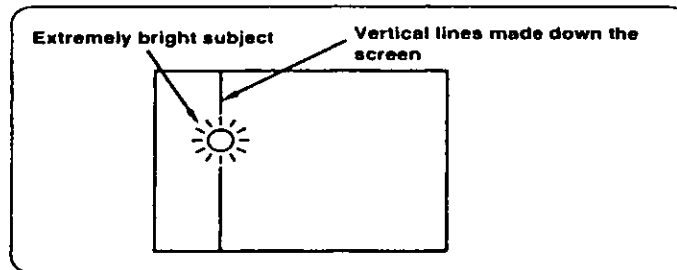

Flicker

Flickering may occur if fluorescent lights are used for the lighting. This is the case in areas where the commercial power line frequency is 50 Hz or when a high shutter speed is used. To prevent flicker, set the electronic shutter speed to 1/100 where the commercial power line frequency is 50 Hz and to OFF where it is 60 Hz.

Moiré

Shooting a subject with striped patterns may give rise to the formation of Moiré patterns.

White streaks

White streaks may appear at high temperatures. They may be more conspicuous when the gain has been increased.

Picture roughness

Roughness in a specific pattern may appear all over the screen when the temperature is extremely high.

Troubleshooting

If you suspect trouble in your unit, proceed with the inspections or adjustments described below. Consult your dealer if the trouble persists even after you have taken the remedial action suggested.

Symptom	Inspection/adjustment	Reference page no.
<ul style="list-style-type: none"> • The power fails to come on. 	<ul style="list-style-type: none"> • Check if the battery still has a sufficient charge. • Check if the AC adaptor has been connected securely. 	—
<ul style="list-style-type: none"> • The low battery warning is given (BATT LED or TALLY LED lights or flashes). 	<ul style="list-style-type: none"> • Check if the battery still has a sufficient charge. • Check if the battery setting menu item has been set correctly. If the AC adaptor is being used, use the NiCd12 setting for the battery selection menu item. 	15, 50
<ul style="list-style-type: none"> • The "BACKUP BATTERY EMPTY" message appears when the power is turned on. • The real time is not correct. 	<ul style="list-style-type: none"> • The back-up battery may have reached the end of its service life (approx. 1 year). Consult with your dealer and replace it with a new one. 	16, 58
<ul style="list-style-type: none"> • No operation results when the function buttons are pressed. 	<ul style="list-style-type: none"> • Check the viewfinder for error messages. 	16, 17
<ul style="list-style-type: none"> • The tape cannot be fast forwarded or rewind. 	<ul style="list-style-type: none"> • Check if the tape has already been fast forwarded or rewind all the way to the end or beginning of the tape. 	—

Condensation

Condensation may form on the head cylinder when the unit is moved from a cold location into a warm room or when it is operated in a humid environment.

The principle behind this phenomenon is the same as when droplets of water form on the window panes of a heated room.

These droplets are called condensation. If the tape is made to travel when condensation has formed, the head cylinder and tape may be damaged.

Take the following precautions regarding condensation:

- Before inserting the cassette tape, set the power switch to ON, and check that the VTR LED or TALLY LED is not lighted or flashing and that the HUMID display is not lighted on the display panel.
- Whenever possible, avoid operating the unit in situations where condensation is likely to form.
- When the unit is to be moved, remove the cassette tape before moving it.
- If the HUMID display flashes while the cassette tape is already loaded, take the following steps.
 1. Turn on the power.
 2. Press the EJECT button to eject the cassette tape.
 3. Wait until the HUMID display stops flashing.
 4. Once the HUMID display has stopped flashing, insert the cassette tape and run it.
 5. Check that no trouble occurs.

Emergency eject

If the cassette cannot be ejected by pressing the EJECT button, use a screwdriver or similar tool to press and turn the EMERGENCY screw. This enables the cassette to be removed.

1 Set the power to OFF.

2 Remove the rubber cap where shown in the figure. Insert a Phillips head screwdriver into the cross-shaped part of the EMERGENCY screw (red).

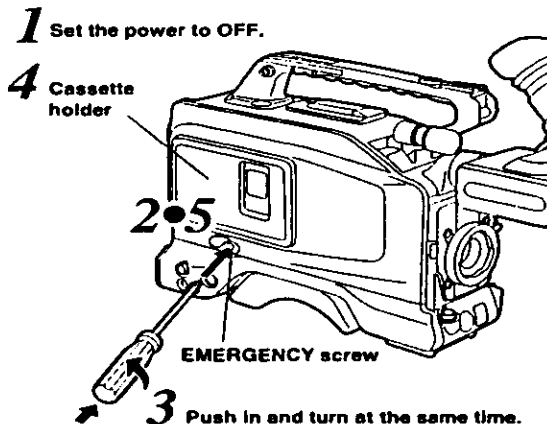

- This screw needs to be rotated through about 30 turns after the first turn until the unloading can be started.
- This screw needs to be rotated through about 120 turns after the first turn until the tape is ejected.

3 While pushing in with the screwdriver, turn the EMERGENCY screw counterclockwise until the tape is ejected.

- This screw needs to be rotated through about 30 turns after the first turn until the unloading can be started.
- This screw needs to be rotated through about 120 turns after the first turn until the tape is ejected.

4 Remove the cassette.

5 Return the rubber cap to its original position.

<Notes>

- Do not turn the EMERGENCY screw except in an emergency.
- Do not turn the screw clockwise. Stop turning the screw as soon as the tape is ejected. Otherwise, the mechanism may be damaged.
- After the tape is ejected, the cassette holder will not lock into place even when an attempt is made to close it. Be sure to turn the power off and turn it back on to reset the mechanism's operation, and then close the cassette holder.
- A clicking sound will be heard when the EMERGENCY screw is turned: this sound is made by the reel drive operation and is therefore not indicative of a malfunction.

Maintenance

- The unit has a precision-made construction inside which is designed to deliver a high performance. Take care to conduct proper maintenance in order to keep the unit in perfect working order for many years to come. Sophisticated technology and equipment are required to replenish the oil, replace the parts or adjust the electrical components. Consult your dealer as to when these steps need to be taken.
- Failure to adhere to the maintenance and inspection routine, which involves removing the dirt and dust from inside, replenishing the lubricating oil and replacing the worn parts (such as heads), will make it impossible for the unit to produce quality pictures and proper recordings. It will also shorten the unit's service life. Ensure that the unit is maintained and inspected well ahead of time.

Cleaning the heads

When the heads need to be cleaned, use the AJ-CL12LP cleaning cassette. Follow the handling instructions accompanying the cleaning cassette since the video heads may be damaged if it is used incorrectly.

Cleaning the lens

- Maintain and inspect the lens once a year.
- Wiping the lens may leave scratches on it. Use an air blower or a brush with soft bristles to blow or brush away the dirt or dust which may have accumulated on the lens surface.
- If grease or fingerprints have been left on the lens, use a lens cleaner available from a camera shop, and wipe the lens starting from its center. Make circular motions and work toward the edges.

Ensure that droplets of water will not find their way to the lens when shooting in rainy or snowy conditions.

Once the lens has been removed from the camera, attach the lens cap to prevent dust and dirt accumulating on the inside of the lens.

Cleaning the viewfinder

- Do not use paint thinners or other solvents to remove dirt on the viewfinder.
- Use a lens cleaner available from a camera store to wipe the lens.
- Under no circumstances must the mirrors be touched. Use an air blower available from a camera store to blow away any dirt or dust which may have accumulated on them.

Panasonic